



TIMTOS APP



Wechat

The official show daily of TIMTOS 2019

Highlighting Industry 4.0, Smart Manufacturing & AI Technology



## Contents

What's On at TaiNEX 2 . . . . .	P3
Show Updates . . . . .	P5
Industry Updates . . . . .	P7
Exhibitor Interview . . . . .	P9-11
Special Report . . . . .	P12
Exhibit Highlights . . . . .	P16-19
展覽新聞 . . . . .	P24-25
南港2館專欄 . . . . .	P27
工業資訊 . . . . .	P29
專題報導 . . . . .	P30-31
參展商採訪 . . . . .	P32-34
產品報導 . . . . .	P36-38



Mr. James C. F. Huang  
Chairman, TAITRA

**D**istinguished guests and visitors,  
welcome to TIMTOS 2019!

First of all, I would like to thank the Ministry of Economic Affairs, Taipei City Government and those who have put their tremendous efforts in establishing the Taipei Nangang Exhibition Center, Hall 2 (or TaiNEX 2 for short) from start to finish.

Today marks a milestone not only for Taiwan's economy and MICE industry but also for TIMTOS, as we celebrate the grand opening of TaiNEX 2. With the completion of TaiNEX 2, the Taipei Nangang Exhibition Center (TaiNEX) becomes the biggest exhibition venue in Taiwan and makes

>> Go to P1  
(Top half)



Mr. Alex Ko  
Chairman, TAMI

**T**hank you, our honored guests from the industry, the academies, and the government, our buyers from both Taiwan and abroad, and the media, thank you for coming to 2019 Taipei Int'l Machine Tool Show. On behalf of Taiwan Association of Machinery Industry, I would like to thank for your support for the event.

### Biggest Show Ever to Announce Innovation Development Competition

Benefited from the completion of Taipei Nangang Exhibition Center, Hall 2, TIMTOS

>> Go to P1  
(Bottom half)

攤位號 J0330

## 全球第三大工具機集團

World 3<sup>rd</sup> Largest Machine Tools Group

全球 37 大品牌 · 50 個生產基地

37 Brands and 50 Production Bases Worldwide



## Smart, Exquisite And Exceptional Mechanical



**FX-800**



**MX-800**



**LA-250YS**

Integrated and sustainable technology inspires end-users in flourishing industries Taiwan TAKISAWA has strong applications in a broad range of sectors, the critical technology advancements in TAKISAWA's upgraded multi-tasking centers and high rigidity vertical machining centers have expressed the potential to spark greater mechanical breakthroughs in the downstream of sectors, such as electric vehicles, automobiles, medical orthopedic device manufacturing, and precision aerospace components. The CNC lathes' cutting capacity is particularly popular among clients in the electric vehicle sector due to the highly integrated features of TAKISAWA's machine.

In the lab, TAKISAWA keeps experimenting the possibility to integrate as much machining power and speed possible into one single CNC lathe. It embodied TAKISAWA's multi-tasking centers with accurate machining, such as milling, drilling and high quality turning.

Taiwan TAKISAWA examined the demands of modern manufacturing as the tough issue they must deal when verifying workpieces and differing industries in the factory floor. This concern stems from the speedy development of IoT and digitalization in traditional manufacturing sector.

The aspect of being able to interact with TAKISAWA clients, and the connectivity to the application industries have been encouraged by Industry 4.0, naturally Taiwan TAKISAWA must respond and design versatile equipment that empowers our users to be able to take production contracts from all-sorts of industries", Tai remarked.

The major application fields of Taiwan TAKISAWA's clients are in automotive mold-die manufacturing, gear box and key component manufacturing. Several top-tier sports and commercial vehicles, and high-profile electric vehicle companies are long term collaborators with Taiwan TAKISAWA.

TAKISAWA leads the future with edge-cutting techniques with modular, smart designs About the future for Taiwan TAKISAWA's development, the future of TAKISAWA's mechanical focus would be in "modular designs" of machine tools. It would allow greater flexibility for machine tools to be involved in more innovative applications.

Having inherited the Japanese industrial art DNA, Taiwan TAKISAWA integrates Taiwan innovation in their CNC lathes. They create an even stronger multi-purpose CNCs and vertical CNCs that top the demands from industrial countries, like Japan and Germany. In an era of Industry 4.0, the company's manufacturing equipment will keep upgrading and optimizing to intelligent platform. The intelligent platform aims to analyze production, improve the database for big data manufacturing, incorporate industrialization and digitalization, and finally generate new markets. TAKISAWA would soon become the total solution provider and CNC machining expert. Exceeding the merits of their Japanese upbringing, the 'TAKISAWA' spirit can now be seen across crucial global manufacturing centers. It is a spirit that creates, innovates, reflects and reaches brilliance.

**Taiwan TAKISAWA Technology Co., Ltd.**

+886-3-4643166

@ info@takisawa.com.tw

www.takisawa.com.tw



**>> From C1: TAITRA**

Taiwan one of the most important and ideal destinations for international exhibitions, meetings and events.

The completion of TaiNex 2 opens up the opportunity for exhibitions held in Taiwan to increase their sizes and scales. And today, we are about to witness the first trade show held at this new venue, TIMTOS! Because of TaiNex 2, TIMTOS is able to expand its exhibition scale to 7,000 booths, creating a new record high in Taiwan's exhibition history, and making it the world's 3rd largest machine tool trade show.

We are now living in a world where

digitalization has a huge impact on our businesses, productivity and everyday life. Companies in Taiwan are capitalizing on advanced ICT and digital technology to improve productivity and spur industrial development.

The Taiwanese machinery industry is no exception. With an integrated supply chain and strong R&D capabilities, machinery companies apply new technologies to develop smart machines and total solutions to assist manufacturers construct smart factories to optimize productivity.

TIMTOS has also evolved with global industrial revolutions, from the era of mass production to Industry 4.0.

This year, TIMTOS highlights 'Industry 4.0', 'Smart Manufacturing', and 'AI Technology'. You will be able to see integrated systems and digital solutions that incorporate machine tools with industrial robots, sensors, IoT, big data analysis, machine learning and AI technology to make automated production lines more efficient and resilient.

Moreover, we host the TIMTOS Summit to assist manufacturers to master the latest industry trends. Top executives from world renowned brands and industry experts offer their insights on future trends in four topics— 'Machine Intelligence and AIoT', 'Additive Manufacturing',

'Automotive Manufacturing Revolution' and 'Innovation in Aerospace Manufacturing'. The Summit will undoubtedly be insightful and inspirational.

Facing the fast-changing economic situation and digital revolution, it is TAITRA's mission to assist companies promote their latest innovation, connect with overseas markets and help realize innovative ideas to make Taiwan the island of Smart Manufacturing.

Thank you, and I wish you all a great time at TIMTOS 2019. ■

**Mr. James C. F. Huang**  
**Chairman, TAITRA**

**>> From C1: TAMI**

becomes the world's 3rd largest machine tool show, only next to EMO and IMTS. This year there will be 1,230 exhibitors joining us in 7,000 booths, making a new record high in the show's history.

Echoing "Industry 4.0 & Smart Manufacturing", the theme of this year's show, smart machinery is included as a special category in this year's competition of Taiwan Machine Tool Industry Awards for Excellence in Research and Innovation to encourage innovation and development of the industry. There are total 43 entries this year that will be reviewed by notable committees in the field of machinery tool design and manufacturing. The competition will be conducted by product categories and subcategories. The result of the intense competition will be announced tomorrow night at the dinner reception.

**Cultivation of Post-Secondary and Higher Education, Elevation of Collaboration with the Industry, the Academy and the Government**

TIMTOS serves more than as a stage for global manufacturers to show their products, it is also a place for recruiting the best talents. This year students take great initiative to learn from the show, with more than 7,200 students coming from 141 classes of 53 schools, many times more than that of the previous year. We appreciate the promotion by Ministry of Education and related sectors, through which we are able to run the event smoothly, while realizing the practical learning of post-secondary and

higher education.

In addition to the participation of ITRI and PMC (Precision Machinery Research Development Center) in the show, we are also joined by new faces such as Chung Cheng University, Formosa University, and the Global Research & Industry Alliance of the Department of Engineering and Technology of Ministry of Science and Technology. We expect even more professionals to join the show in the future.

**Rooting in Smart Machine and Smart Manufacture, Looking up to 2 Trillion Production Value**

Taiwan Machinery industry continues to grow. As in 2017, the industry production value has exceeded TWD1.1 trillion. In 2018, the export value of machinery industry was USD27.4 billion, a 7.2% increase from last year, while the production value increased by TWD80 billion and reached TWD1.18 trillion, representing a 7.3% growth and creating new history records. The export value of machinery tool was USD3.66 billion, increased by 9.5% compared to last year.

Last August, TAMI published the industry white paper of smart machinery, planning to continue on the direction of smart machine and smart manufacturing to become the world's capital for producing smart machine. Smart machine is the foundation of smart manufacturing, as there will be no smart manufacturing without smart machine.

This year, TAMI will facilitate and support the smart machine to connect to the

cloud and build a team to help construct a cloud service platform specifically for machines and to demonstrate and promote this platform to the equipment manufacturers. This will add values to the machinery industry and help the industry to reach to the TWD2 trillion production value by 2025.

**2019 is the Year of Economy Rebound, Planning for the New Southbound Policy While Observing the U.S.-China Trade Dispute**

Since more than 70% of Taiwanese machine tool products are being exported, the future of the industry relies on global economy. Capital expenditures tightened since the 4th quarter of last year, and companies are still waiting for further signs. Although partial machine manufacturers have received orders, the trade dispute between U.S. and China and the Brexit hold back the economy nonetheless. We are taking conservative steps while the second half of 2019 could be more promising than the 1st half, the overall economy is looking to rebound.

To respond to the trade dispute, the need to set up a second production location abroad is increasing, especially the business opportunities in Vietnam and India. This year the show expects to receive a potential order of USD1.6 billion, about 5-10% annual industry growth. The industry expects to grow by 10% accompanied by a favorable 2nd half of the year.

**The Industry Expects to**

**Increase Competitiveness Under Government's Support**

To react to the ever-changing global economy, we expect that the government to protect the export of Taiwan machines, and hope that the Central Bank to activate the defensive depreciation mechanism to avoid the impact that Taiwan dollar exchange rate has on machine export.

Secondly, we hope that the government can create a category for machinery; and assist machinery companies to be listed on the stock market, as well as assisting them financially to increase the number by 50 companies in the next 3 years.

We also expect that the Legislative Yuan to pass the draft revision of industry innovation regulation and include smart machine under the items of investment tax credit to help increase industry competitiveness.

With the effort from multiple sectors, this year TIMTOS has broken many new records, such as becoming the largest professional trade show in Taiwan. In the future, for the machine industry and Taiwan, we shall accomplish greater achievement with modest, humble and firm steps.

Thank you again for the presence of our government officials, honored guests, and the media at the show. We are encouraged with and supported by everyone's participation. I'd like to wish you a great business in the future, thank you. ■

**Mr. Alex Ko**  
**Chairman, TAMI**

# TIMTOS 2019 EVENT / SEMINAR PROGRAM

Date	Time	Event/Seminar	Organizer	Venue	Remarks
3/4 (Mon.)	10:30	Opening Ceremony	TAITRA, TAMI	Lobby, 4F, Taipei Nangang Exhibition Center, Hall 2	By Invitation Only, Miranda Chien +886-2-27255200#2867
	8:00-17:00	Bfuture Global Launch & Products Announcement	Ching Hung Machinery & Electric Industrial Co., Ltd.	Room 402c, Taipei Nangang Exhibition Center, Hall 1	+886-4-23509188#527
	8:00-17:00	Fagor CNC & Feedback Systems Products Introduction	Fagor Automation Taiwan Co., Ltd.	Room 602, Taipei Nangang Exhibition Center, Hall 2	Samuel Wen +886-4-23851558
	13:30-16:30	TIMTOS 2019 Procurement Meetings	TAITRA	Room 504, Taipei Nangang Exhibition Center, Hall 1	Tina Ko +886-2-27255200#1573
	14:00-15:00	Press Conference, TIMTOS 2019	TAITRA TAMI	Room 403, Taipei Nangang Exhibition Center, Hall 1	Savannah Hou +886-2-23494677
	16:00-17:30	Market Briefing of Machinery Industry in Malaysia & Signing Ceremony for the Memorandum of Understanding between Penang Foundry & Engineering Industries Association (PENFEIA) and Taiwan External Trade Development Council (TAITRA)	TAITRA	Room 404, Taipei Nangang Exhibition Center, Hall 1	Melody Chen +886-2-27255200#2693
3/5 (Tue.)	8:00-17:00	Bfuture Global Launch & Products Announcement	Ching Hung Machinery & Electric Industrial Co., Ltd.	Room 402c, Taipei Nangang Exhibition Center, Hall 1	+886-4-23509188#527
	8:00-17:00	Fagor CNC & Feedback Systems Products Introduction	Fagor Automation Taiwan Co., Ltd.	Room 602, Taipei Nangang Exhibition Center, Hall 2	Samuel Wen +886-4-23851558
	8:30-12:00	Intelligent Manufacturing and Machine Tool Key Component Application Technology	Intelligent Machinery Technology Center, ITRI	Room 505a, Taipei Nangang, Exhibition Center, Hall 1	Helena Chang +886-49-2345309
	9:00-12:00	台日機械企業經貿交流會	TAMI	Room 504bc, Taipei Nangang Exhibition Center, Hall 1	+886-2-23494668
	9:00-16:00	TIMTOS 2019 SUMMIT	BOFT, MOEA	Room 101, TICC	Lilyan Kao +886-2-27255200#2679
	16:00-17:00	German Company Talk @ TIMTOS	TAITRA German Trade Office Taipei	Room 101, TICC	Suzie Cheng +886-2-7735-7524
	10:00-12:00	Renishaw's XK10 alignment laser system-new tool for machine tool assembly and alignment	Renishaw (Taiwan) Inc.	Room 402a, Taipei Nangang Exhibition Center, Hall 1	Eric Chuang +886-4-24603799
	10:30-12:00	TNC 640 高效率五軸輪廓控制器 - 高可靠度創新加工技術的優勢	HEIDENHAIN Co., Ltd. (Taiwan)	Room 403, Taipei Nangang Exhibition Center, Hall 1	Gloria Tsai +886-4-2358-8977 #1035
	13:00-15:00	NIDEC- Commander C Product Launch	Raise Precision Co., Ltd.	Conference Room 4, TWTC Exhibition Hall 1	Judy Chen +886-4-22606502
	13:00-15:00	Industry 4.0- Intelligent Manufacturing Conference/Mold intelligent production unit	Accutex Technologies Co., Ltd.	Room 402ab, Taipei Nangang Exhibition Center, Hall 1	+886-4-23599688#226
	14:00-15:00	JIMTOF 2020 Press Conference	Japan Machine Tool Builders' Association	Room 404, Taipei Nangang Exhibition Center, Hall 1	Keiko Honda +81-3-34343961
	14:30-16:30	智慧製造聯網數據加值產業聯盟會員大會	ITRI	Room 504a, Taipei Nangang Exhibition Center, Hall 1	+886-3-5916720
	15:00-16:00	臺灣機械工業同業公會與馬來西亞檳城機器廠商會簽訂合作協議	TAMI	VIP Briefing Room, 4F, Taipei Nangang Exhibition Center, Hall 1	Ryan Lin +886-2-23494694
	15:00-17:30	Litz Hitech Global Dealer Meeting and New Product Announcement	Litz Hitech Corporation	Room 401, Taipei Nangang Exhibition Center, Hall 1	Lisa Mo +886-4-26815711#246
	18:30	Reception for TIMTOS 2019 and the Ceremony of Taiwan Machine Tool Industry Awards for Excellence in Research & Innovation	TMTF, TAITRA, TAMI	The Banquet Hall, 3F, Taipei Nangang Exhibition Center, Hall 1	Bonnie Tsai +886-2-23110358
3/6 (Wed.)	8:00-17:00	Bfuture Global Launch & Products Announcement	Ching Hung Machinery & Electric Industrial Co., Ltd.	Room 402c, Taipei Nangang Exhibition Center, Hall 1	+886-4-23509188#527
	8:00-17:00	TIMTOS 2019 High School, University Students Guided Tour	TAMI	Room 500, Taipei Nangang Exhibition Center, Hall 1	+886-2-23494672
	8:00-17:00	Fagor CNC & Feedback Systems Products Introduction	Fagor Automation Taiwan Co., Ltd.	Room 602, Taipei Nangang Exhibition Center, Hall 2	Samuel Wen +886-4-23851558
	9:00-16:00	TIMTOS 2019 SUMMIT	BOFT, MOEA	Room 101, TICC	Lilyan Kao +886-2-27255200#2679
	16:00-17:00	German Company Talk @ TIMTOS	TAITRA German Trade Office Taipei	Room 101, TICC	Suzie Cheng +886-2-7735-7524
	8:00-17:00	The Trend of Industry 4.0 and Intelligent Machinery Technical Application Seminar	igus Taiwan Company Ltd. CTIMES	Room 505, Taipei Nangang Exhibition Center, Hall 1	KF Sun +886-2-25855526#225
	9:00-11:00	YCM Dealer Meeting	Yeong Chin Machinery Industries Co., Ltd.	Room 401, Taipei Nangang Exhibition Center, Hall 1	Claire Chen +886-4-25623211#1812
	10:30-12:00	選擇美國投資研討會 - 錢進美國教戰守則	AIT TAMI	Room 501, Taipei Nangang Exhibition Center, Hall 1	Jackie Hong +886-2-27201550#334
	13:00-17:00	New Product Launch	Vision Wide Tech Co., Ltd.	Room 502, Taipei Nangang Exhibition Center, Hall 1	Michelle Huang +886-4-22712000#231
	13:00-17:00	Goodway Group New Product Launch Event	Goodway Group	Room 504a, Taipei Nangang Exhibition Center, Hall 1	Lisa Chiang +886-4-24629698#62107
	13:30-16:30	Application of mineral casting (polymer composite) in machinery field	Shandong Nano Advanced Materials Technology Co., Ltd.	Room 304, Taipei Nangang Exhibition Center, Hall 1	+86-531-88917773
13:30-17:00	中國砂輪新產品發表會	KINIK COMPANY	Conference Room 2, TWTC Exhibition Hall 1	+886-2-26791931#3309	
3/7 (Thu.)	8:00-17:00	直得科技新品說明會	Chieftek Precision Co., Ltd.	Room Happiness, 3F, Taipei Nangang Exhibition Center, Hall 1	+886-6-5055858#162
	8:00-17:00	Bfuture Global Launch & Products Announcement	Ching Hung Machinery & Electric Industrial Co., Ltd.	Room 402c, Taipei Nangang Exhibition Center, Hall 1	+886-4-23509188#527
	8:00-17:00	TIMTOS 2019 High School, University Students Guided Tour	TAMI	Room 500, Taipei Nangang Exhibition Center, Hall 1	+886-2-23494672
	8:00-17:00	Fagor CNC & Feedback Systems Products Introduction	Fagor Automation Taiwan Co., Ltd.	Room 602, Taipei Nangang Exhibition Center, Hall 2	Samuel Wen +886-4-23851558
	13:30-17:00	2019 台北國際工具機展 GLORIA 智慧製造創新應用論壇	MOST, TAITRA, TAMI	Room 402ab, Taipei Nangang Exhibition Center, Hall 1	Jessica Guo +886-2-25774249#827
	14:00-16:00	Energy Saving Technology for Hydraulic System and Filtration of Cooling Lubricant	HYDAC Technology Ltd. Sterling TSI Co., Ltd.	Room 502, Taipei Nangang Exhibition Center, Hall 1	Jojo Yang 886-4-22602278
	14:00-16:00	Improving the quality and efficiency of grinding processing	Join Star Trading Co., Ltd.	Room 505b, Taipei Nangang Exhibition Center, Hall 1	Jamie Chang +886-2-29115226#607

Subject to change without notice.

# TaiNEX 2 Opens on March 4, 2019



**T**aipei Nangang Exhibition Center, Hall 2 (TaiNEX 2), an expansion project invested by the Ministry of Economic Affairs (MOEA) and operated by Taiwan External Trade Development Council (TAITRA), opens its door on March 4, 2019.

TNEX 2's first exhibition is heavy weight trade show—TIMTOS 2019, the world's 3rd and Asia's 2nd largest machine tool show!

TaiNEX 2 is the first exhibition hall awarded the "Golden-Level Green Building Label" in Taiwan. It offers 156,700 sqm floor

space to accommodate 32,000 visitors for exhibitions, conferences, business meetings and events. Convenient transportation connected to two metro lines. 1,296 parking space, show grounds with 12-meter ceiling height on 1st floor and 9-meter ceiling height on 4th floor are the features of TaiNEX 2 to attract event organizers to use.

The multifunctional conference hall on the 7th floor, will open in November this year. It is in conjunction with 6,100 sqm outdoor sky garden space where one can see Taipei 101 attracts professional conference organizers to book their events. For example, Rotary International Convention in 2021 will be held at both TaiNEX 1 and TaiNEX 2.

TaiNEX 1 and TaiNEX 2 are expected to become the core venues of Taiwan's MICE industry, as well as one of the major convention and exhibition centers in Asia. The total capacity of these two halls hold more than 5,000 booths and 38 meeting rooms. Because of TaiNEX 2 providing more exhibition space, the scale of TIMTOS

2019 expands to 7,000 booths, nearly 30% increase and a record high for TIMTOS to promote the machine tool industry and supply chain. More Taiwan International trade shows such as the Taipei Cycle Show and Computex Show will also benefit from the opening of TaiNEX 2 in expanding their exhibition scale.

TaiNEX 2's sparkling roof is designed to symbolize ocean waves, in keeping with the nautical theme of TaiNEX 1's rooftop which resembles a ship's mast. TaiNEX 1 and TaiNEX 2 look forward to working with the MICE industry to sail onto new international MICE markets together, and the ranking of Taiwan's MICE activities in Asia-Pacific region will raise up quickly. ■

**TaiNEX 2 Press information contact window :**  
**Macy Chen**  
 Senior Project Manager  
 Nangang International Exhibition Center, Hall 2  
 02-2725-5200 #6616  
 macy@taitra.org.tw

## BLÚ R-Evolution, The high-end solution on machine tools

**B**LÚ - one cable control network - represents a revolutionary concept of networking inside machine tools.

At this years' TIMTOS, Marposs, a worldwide leader in metrology and control in the production environment, will be introducing a high-end solution on machine tools.

Machine tool world is nowadays characterized by more and more flexible machines, able to keep under control process and information in a smart and efficient way. The answer from Marposs to this evolution is called BLÚ, which represents a revolutionary concept of networking inside machine tools.

BLÚ - one cable control network - is an innovative system able to connect real time all monitoring sensors inside a machine, using a single cable. The system consists of a main unit, the Master Node, placed inside the machine cabinet (Dry Area). Starting from here one single cable (MMSB

- Marposs Measure Sensor Bus) goes inside the working area (Wet) and connects all the Function Nodes, which are directly connected to the sensors.

This new "chain" structure is far more flexible and customizable if compared to previous approach, that was similar to a star and included multiple long cables - all going from cabinet to the sensors in the working area.

Machine interfacing is made by the Master node and could be through Fieldbus or parallel I/O. Functions Nodes can be connected directly to each other, or through the MMSB cable, depending on the machine layout.

The technological benefit lies in being able to customise the system layout and "tailor" it to the machine layout, but that is not all. Once the system has been defined, more functions can be added: just add one or more Nodes to the chain at a later time.

One additional innovation on layout is represented by the display, which is a

7" capacitive touch screen - a big step forward from previous solutions which had smaller screens with physical buttons.

BLÚ opens the door to what is today defined "Smart Factory" - with the target of providing a more and more optimized and integrated process through the monitoring of key data/parameters acquired from the system.

It is possible to acquire a Big Data amount from all sensors inside the machine. Different data are available for different levels, starting from the operator sitting in front of the machine and monitoring all working parameters in order to keep the process under control, up to maintenance or ERP.

These data can represent "real time"



BLÚ: the high-end solution on machine tools

parameters - acquired from sensors and provided with watch points - or can be processed and stored for different types of analysis. ■

**To find out more, visit our booth at TIMTOS, Nangang Hall, P0320, or visit our websites: [www.blu.marposs.com](http://www.blu.marposs.com) and [www.marposs.com](http://www.marposs.com)**

## TIMTOS 2019 EVENT / SEMINAR PROGRAM

3/8 (Fri.)	8:00-17:00	直得科技新品說明會	Chieftek Precision Co., Ltd.	Room Happiness, 3F, Taipei Nangang Exhibition Center, Hall 1	+886-6-5055858#162
	8:00-17:00	Bfuture Global Launch & Products Announcement	Ching Hung Machinery & Electric Industrial Co., Ltd.	Room 402c, Taipei Nangang Exhibition Center, Hall 1	+886-4-23509188#527
	8:00-17:00	TIMTOS 2019 High School, University Students Guided Tour	TAMI	Room 500, Taipei Nangang Exhibition Center, Hall 1	+886-2-23494672
	8:00	Fagor CNC & Feedback Systems Products Introduction	Fagor Automation Taiwan Co., Ltd.	Room 602, Taipei Nangang Exhibition Center, Hall 2	Samuel Wen +886-4-23851558
	9:30-18:00	智慧製造論壇	Fusionmedium TAITRA	Conference Room 4,5, TWTC Exhibition Hall 1	Sica Lin +886-2-87715865#180
	9:30-14:00	Diplomatic Motion Solution Product Training and Conference	Diplomatic MS S.p.A Ace Pillar Co., Ltd.	Room 502, Taipei Nangang Exhibition Center, Hall 1	+886-2-29958400#1232
	10:00-17:00	中興大學與精密機械研究發展中心智慧機械產學論壇技術成果發表會	國立中興大學 & 財團法人精密機械研究發展中心	Taipei Nangang Exhibition Center, Hall 1	+886-4-22858139
3/9 (Sat.)	13:00-16:00	3D Printing+3D Scanning	Road Ahead Technologies Consultant Corp	Room 404, Taipei Nangang Exhibition Center, Hall 1	Evelyn Lin +886-2-2999-6788#284
	8:00-17:00	TIMTOS 2019 High School, University Students Guided Tour	TAMI	Room 500, Taipei Nangang Exhibition Center, Hall 1	+886-2-23494672
	8:00-17:00	Fagor CNC & Feedback Systems Products Introduction	Fagor Automation Taiwan Co., Ltd.	Room 602, Taipei Nangang Exhibition Center, Hall 2	Samuel Wen +886-4-23851558

Subject to change without notice.

# 程泰集團

AWEA

GOODWAY

EXTRON

新世代智能化控制 / 全方位的加工對策

# 攜手邁向智慧製造

## SMART MANUFACTURING STARTS HERE!

**AiLINC** COMING SOON

**i Console**

**G.LINC**  
**G.NET**



**GRW series**

走頭式外圓磨床

Traveling Head Cylindrical Grinder



**RG5 series**

天車式高速五軸加工機

High Speed Gantry Type 5-axis Machining Center



**GVF series**

高剛性立式車銑複合機

Super Rigid Vertical Turning Center

**TIMTOS**

2019 台北國際工具機展

南港 1 館  
攤位號碼：

# I 0816

**AWEA** 亞崙機電



亞崙機電股份有限公司  
AWEA MECHANTRONIC CO., LTD.  
+886-4-2462-9698 sales@awea.com  
www.AWEA.com

**GOODWAY** 程泰機械



程泰機械股份有限公司  
GOODWAY MACHINE CORP.  
+886-4-2463-6000 goodway@goodwaycnc.com  
www.GOODWAYCNC.com

**EXTRON** 益全機械



益全機械工業股份有限公司  
YIH CHUAN MACHINERY INDUSTRY CO., LTD.  
+886-4-2359-3351 sales@extroncnc.com  
www.EXTRONCNC.com

## World Class Smart Industry Solutions by German Market Leaders

The concept of smart industry is currently having a deep impact on industrial technologies and production systems. Smart industry and its intelligent manufacturing systems rely on mechanical engineering, one of the core industries in Germany. In 2016, the mechanical engineering industry was the second largest industrial sector in Germany with over 1 million employees and achieved revenues of more than EUR 270 billion. Precision, quality and efficiency serve as the foundation of global success and the international reputation of German mechanical engineering companies.

As one of Taiwan's top four most important trading partners in terms of machine tools, German companies have been providing the necessary tools to Taiwanese companies to answer the current challenges of smart manufacturing such as implementing efficient and individual production by decentralization as well as dynamic self-organization. Due to their

expertise gained over many years and as global leaders in the field of innovative production technology and manufacturing R&D in the machinery industry, German companies fulfill all prerequisites necessary to serve as a smart industry pioneer.

After a successful German Pavilion at TIMTOS 2017, the German Pavilions at TIMTOS 2019, organized by DEinternational in cooperation with the German Trade Office Taipei, will introduce the following 25 leading German machinery companies, which will be presenting the best mechanical engineering products from Germany:

Atlas Technologies Machinery Co. Ltd., Balluff Taiwan Ltd., Blum Production Metrology Co. Ltd., Golden Leader Camel Ent. Co. Ltd., GTW Taiwan Ltd., HAWE Hydraulic Technology (Shanghai) Co. Ltd., Interact Inc., KTR Kupplungstechnik GmbH, Mong Tec Enterprise Co. Ltd., Nano-Trend Technology Co. Ltd., OPEN MIND



Technologies Taiwan Inc., Phoenix Contact Co. Ltd., Schenck Shanghai Machinery Co. Ltd., SCHUNK Intec Taiwan Ltd., SMW-AUTOBLOK Spannsysteme GmbH, Stober, WTO GmbH, Yonchin Enterprise Inc. (all at the Nangang Exhibition Center - Hall 1, 4F) as well as CyTec Zylindertechnik GmbH, DWT GmbH, EUCHNER GmbH + Co. KG, Honsberg Metalsagen GmbH, Importech Corporation, Precitec Asia Ltd., ZF Friedrichshafen AG and Ziersch GmbH **Welcome to German Pavilions at TIMTOS (Nangang Exhibition Center- Hall 1, 4F & Taipei World Trade Center - Hall 1).** ■

The German Trade Office also welcomes all guests to join our Happy Hour at the German Pavilions!

As a traditional event at the German Pavilion, we sincerely welcome you to enjoy a free flow of German Hofbräu beer kindly sponsored by RheinSinn Enterprise Ltd. as well as finger food with us while visiting the German Pavilion.

•March 7 (Thu.) from 15:00 to 17:00 at Nangang Exhibition Center Hall 1, 4th Floor, Area N, at SCHUNK Intec Taiwan's booth (N0512)

•March 8 (Fri.) from 15:00 to 17:00 at TWTC Hall 1 Area A at aisle between A1222 and A 1212.

A prize quiz will also be held during the Happy Hour. Welcome to join us!

For further information contact Ms. Suzie Cheng  
Tel: +886-2-7735-7524

Email: cheng.suzie@taiwan.ahk.de

## Swiss Pavilion shows latest technologies at TIMTOS 2019

Organized by the Trade Office of Swiss Industries and supported by the Swiss Mechanical and Electrical Engineering Industries (Swissmem), the Swiss Pavilion at TIMTOS 2019 presents the latest machine tools and tools technologies through 16 Swiss branches in Taiwan and local representatives. The Swiss pavilion in the Nangang Exhibition Hall (4F) comprises 105 standard booths, totaling 945 sqm, making it the largest national pavilion at the trade show. A wide spectrum of technologies in the fields of grinding, milling, sharpening, turning, jig

boring, electrical discharge machining, gear cutting, and forming are displayed during the exhibition. The prominent Swiss machine tool presence indicates the importance and the vitality of this industry and the undivided concentration on local customers' needs.

### Highlights of the Swiss Pavilion

Rolf Frei, Director of Trade Office of Swiss Industries points out: "Swiss companies showcase innovative and flexible

solutions in the production process. Higher precision, speed and productivity as well as user-friendly controls are of utmost importance to increase competitiveness and upgrade the industry. The Swiss machine tool industry offers a comprehensive production range in the mid to high performance segments of cutting, forming, and special purpose machines. Swiss companies concentrate on demanding technical problems that require new solutions, which are tailored to the customer's specific needs by applying the latest technologies available.

Customers of Swiss machine tools and tools are mainly in the machinery, automotive, aerospace, aircraft, optical medical, micro-mechanic, and watches industries. It has become evident that specialized high-performance machines are often the better alternative than lower priced general-purpose equipment when operating costs such as power consumption, unit cycle times and yield of the manufacturing process are also taken into account." ■

**The Swiss Pavilion in the Nangang Exhibition Center, Hall 1 (4F)**



## U.S. Pavilion will exhibit in TIMTOS 2019

Organized by Commercial Section, American Institute in Taiwan and seven U.S. companies— either branches or agents, a U.S. Pavilion in TIMTOS 2019 will ambitiously show the public the latest technologies of machine tools, machine components, measuring equipment, and CAD/CAM software, etc. The U.S. Pavilion is located at the 4th floor of Taipei Nangang Exhibition Center, Hall 1, with renowned exhibitors from HAAS, OMAX, HEXAGON, Delcam, Martin, ESPRIT, and SUNNEN. The U.S. machinery manufacturers, which benefit from the U.S. Advanced Manufacturing Partnership

(AMP) initiative, are those providing advanced and globally competitive products.

The U.S. Pavilion, covering 28 units of booths, features brands and products as below:

- HAAS: Machining center, Turning
- OMAX: Waterjet cutting
- HEXAGON: Measuring equipment
- Delcam: CAD/CAM
- Martin: Transmission parts
- ESPRIT: CAD/CAM
- SUNNEN: Precision honing equipment

Moreover, there are more than 10 U.S. companies exhibiting in other sections of the show, those including Hardinge, Hurco,

Setco, Gleason, Solid Wizard, Controltek, Saginaw, and Gardner Business Media.

### Highlights of the U.S. Pavilion

The U.S. Pavilion will introduce the innovative manufacturing process and the practical solutions. More precisely, U.S. companies believe products with higher precision, productivity, efficiency, as well as having user friendly characteristics are the key factors to compete in the

global market. Further U.S. companies, which are good at combining the latest technology with traditional craft, will provide tailor-made solutions and solve complex problems. Their customers range from industries of machinery, automation to aerospace, automotive, defense, and energy. ■

**The U.S. Pavilion in the Nangang Exhibition Center - Hall 1, 4F**



# TIMTOS 2019 Summit

Time: 09:00-17:00, Tuesday, March 5, 2019  
Location: Room 101, TICC (No. 1, Sec. 5, Xinyi Road, Taipei)

Time: 09:00-17:00, Wednesday, March 6, 2019  
Location: Room 101, TICC (No. 1, Sec. 5, Xinyi Road, Taipei)

Session 1: Machine Intelligence and AIoT	
Time	Agenda / Speaker
09:00-09:20	Registration
09:20-09:30	Opening Remarks Leonor F. M. Lin, Executive Vice President of TAITRA Alex Ko, Chairman of TAMI
09:30-10:10	【Keynote】 How SAP helps Customers to Create Value with Industry 4.0 and Internet of Things in Discrete Industries Bernhard Meyer, SAP Global Solution Manager, Industry Business Unit, Industrial Machinery & Components (IM&C)
10:10-10:50	【Keynote】 The Intelligent IoT Asset Management Platform for Smart Factory Arthur Liu, Vice President, ITTS
10:50-11:30	【Keynote】 Realization of Taiwan Industrial Internet of Things Application from Industry-University Cooperation Wen-Yuh Jywe, President of National Formosa University
11:30-12:10	【Keynote】 Trends of Industrial AI and Industrial Internet Jay Lee, Professor at the University of Cincinnati
12:10-12:30	【Panel Discussion】 The Future of Work Moderator: K.C. Chuang, Honorary Chairman of TAMI Panelists: All Speakers

Session 2: Additive Manufacturing	
Time	Agenda / Speaker
13:00-13:30	Registration
13:30-14:10	【Keynote】 Advanced Machining Solutions for the Future of Manufacturing Dr. Neun Harald, COO, DMG MORI
14:10-14:50	【Keynote】 The Evolution of Metal Additive Manufacturing: Leveraging the Machine Tool Infrastructure Pascal Pierra, Director of Asia-Pacific, Optomec
14:50-15:20	【Keynote】 Making Production Real Oscar Yang, Sales Director of Great China, Road Ahead Technologies Consultant
15:20-16:00	【Panel Discussion】 Metal Additive Manufacturing - Now & Future Moderator: James Huang, Chief Innovation Officer, Business Next Media Corp Panelists: All Speakers
16:00-17:00	【Side Event】 German Company Talk @ TIMTOS

Session 3: Innovation in Aerospace Manufacturing	
Time	Agenda / Speaker
09:00-09:30	Registration
09:20-10:00	【Keynote】 Master highly dynamic machining strategies with innovative solutions in the field of drive and control technology Peter Topol, Senior Product Manager, Heidenhain
10:00-10:40	【Keynote】 Embracing Industry 4.0 and Transform towards a Digital Future with Siemens Tino Hildebrand, Vice President, Siemens Ltd., Taiwan
10:40-11:20	【Keynote】 The role of the digital collaboration and innovation in the renaissance of the Aerospace Manufacturing Rémi GERMAIN, Aerospace & Defense Industry Sales Director, Dassault Systèmes
11:20-12:00	【Keynote】 Advanced manufacturing technologies Cyrille SCHWOB, Head of Technology, Asia-Pacific, Airbus
12:00-12:30	【Panel Discussion】 Transforming Manufacturing - what can we see in the next 5 years Moderator: Jwu-Sheng Hu, Vice President and General Director, Mechanical and Mechatronics Systems Research Laboratories, ITRI Panelists: All Speakers

Session 4: Automotive Manufacturing Revolution	
Time	Agenda / Speaker
13:00-13:30	Registration
13:30-14:10	【Keynote】 The Technology and Application of Industrial Robotics to New Era of Smart Manufacturing HT Choong, Regional Manager- Service Sales (SAS & Taiwan), ABB
14:10-14:50	【Keynote】 CNC Systems for Factory of the Future Charlie Chen, Division Manager of Industrial & Mobile Application, Bosch Rexroth Taiwan
14:50-15:20	【Keynote】 Intelligent Factory Automation (iFA) for Industry 4.1 Fan-Tien Cheng, Director, Intelligent Manufacturing Research Center, National Cheng Kung University
15:20-16:00	【Panel Discussion】 The Revolution is Speeding Up - Are We Ready? Moderator: Jwu-Sheng Hu, Vice President and General Director, Mechanical and Mechatronics Systems Research Laboratories, ITRI Panelists: All Speakers
16:00-17:00	【Side Event】 German Company Talk @ TIMTOS

\*Topics are subject to change and will be updated anytime.  
\*Chinese/English onsite simultaneous interpretation provided.

## Speakers / Moderators

<p><b>Bernhard Meyer</b> SAP Global Solution Manager, Industry Business Unit, Industrial Machinery &amp; Components (IM&amp;C)</p> 	<p><b>Dr. Neun Harald</b> COO, DMG MORI</p> 	<p><b>Peter Topol</b> Senior Product Manager, Heidenhain</p> 	<p><b>Jwu-Sheng Hu</b> Vice President and General Director, Mechanical and Mechatronics Systems Research Laboratories, ITRI</p> 
<p><b>Arthur Liu</b> Vice President, ITTS</p> 	<p><b>Pascal Pierra</b> Director of Asia-Pacific, Optomec</p> 	<p><b>Tino Hildebrand</b> Vice President, Siemens Ltd., Taiwan</p> 	<p><b>HT Choong</b> Regional Manager- Service Sales (SAS &amp; Taiwan), ABB</p> 
<p><b>Wen-Yuh Jywe</b> President, National Formosa University</p> 	<p><b>Oscar Yang</b> Sales Director of Great China, Road Ahead Technologies Consultant</p> 	<p><b>Rémi GERMAIN</b> Aerospace &amp; Defense Industry Sales Director, Dassault Systèmes</p> 	<p><b>Charlie Chen</b> Division Manager of Industrial &amp; Mobile Application, Bosch Rexroth Taiwan</p> 
<p><b>Jay Lee</b> Professor, University of Cincinnati</p> 	<p><b>James Huang</b> Chief Innovation Officer, Business Next Media Corp</p> 	<p><b>Cyrille SCHWOB</b> Head of Technology, Asia-Pacific, Airbus</p> 	<p><b>Fan-Tien Cheng</b> Director, Intelligent Manufacturing Research Center, National Cheng Kung University</p> 



## China's CNC machine tool possesses huge potential

According to the Analysis Report on Market Demand Forecast and Investment Strategy Planning of China's CNC Machine Tool Industry 2018-2023 released by the Forward Industry Research Institution, China's CNC machine tool industry will still maintain a growth rate of 10-12% in 2018-2023 due to technological development and gradual recovery of the downstream market. By 2023, the market size of China's CNC machine tool industry will exceed RMB 500 billion.

### Automobile industry is still the main market while consumer electronics industry becomes more and more important

Accounting for about 42% of consumption, automobile industry is still the main downstream market. Second is aerospace industry, which accounts for about 18% of consumption. Mold and construction

machinery industry are the third and fourth largest consumer market of CNC machinery, accounting for about 15% and 10% respectively.

In the future, as the smart phone becomes ubiquitous and other electronics products such as tablets, wearable devices get developed and promoted, the 3C industry is in full flourish, while light-cutting CNC machine tools will be in huge demand.

### The imbalance between supply and demand in CNC machine tool are getting worse, the rate of China-made advanced machine is still low

Due to the late start of China's advanced CNC machine tools, the domestic production capacity cannot meet the demand, most of the domestic demands rely on imports. In 2016, over 1,000 sets of high-grade CNC systems specially supported for

research and development of CNC machine tools have been sold, and the domestic market share has increased about 5% from less than 1% before the special launch. In 2017, the localization rate of high-end CNC machine tools in China was about 6%, still very small. However, from the perspective of demand, the demand of high-end CNC machine tools in China reached about 10% in 2013, and it was about 15-20% in 2017, which was a big gap compared with the 6% localization rate.

At present, China needs to upgrade from "manufacturing country" to "manufacturing power". After decades of development, China's CNC machine tool industry has become the world's largest producer and marketer. With rapid development of technology and production capacity, China already has the foundation to respond to the transformation of national manufacturing industry. In the future, China's demand for CNC machine tools will change from medium and low grade to high grade.

### China's CNC machine tool market will exceed RMB 500 billion

The economic development of the 13th five-year plan focuses on the change of economic growth mode.

Advanced manufacturing is the direction of the traditional manufacturing industry upgrading. The development of high-tech industries such as electronic information, biological engineering, new energy and new materials will develop new demands for high precision, high efficiency and specially design CNC machine tools.

The industrial upgrading in eastern

China, the revitalization of old industrial bases in northeast China and the development in central and western regions will provide huge domestic market for the development of the CNC machine tool industry. Economic globalization, the flow of international capital to China, the exchange of international technology and talents, and the strong development of China's international trade will foster a good external environment for the development of China's CNC machine tool industry, giving the CNC machine tool industry a great opportunity to develop.

In the future, China's CNC machine tool industry will mainly present the following three trends:

First of all, the competitiveness of domestic CNC machine tools will be greatly improved, which will lead to a fundamental change of the market share of China-made CNC machine tools.

Secondly, a group of wholly owned enterprises or joint ventures set up by multinational machine tool groups in China, such as DMG, Harting, Mazak and so on, will accelerate its speed of localization to grow its production capacity.

Finally, the industrialization of universal type of CNC machine tool will complete. The universal type of CNC machine tool and the manufacturing center are the fastest developing and the most widely-used equipment to take the biggest proportion of the CNC machine tool consumption. It is reported that the proportion of universal type in CNC machine tool has already exceeded 30%, and its growth rate is much higher than that of other types of machine tools, even the growth rate of the total CNC machine tool. ■

Source: *Int'l Metalworking News for China*



## Here it comes! SCHUNK 5-Fingerhand SVH

Can it be possible that human collaborate with robots? German chancellor Angela Merkel experienced first hand how this can be achieved in the Hannover Messe 2018 during an impressive live demonstration. Angela Merkel got up close and in person with the robotic hands from SCHUNK. Both 5-finger hands of the competence leader for gripping systems and clamping technology are the world's first robotic grippers that have been certified and approved for collaborative use by the German Social Accident Insurance (DGUV).

And now, SCHUNK 5-Fingerhand SVH shows its first appearance in Taiwan, and will be displayed during TIMTOS 2019 in TWTC Nangang Exhibition Hall this March. The series production version of the anthropomorphic SCHUNK 5-finger

hand grips nearly as perfectly as the human hand. The electronics are completely integrated into the wrist, which allows the 5-finger hand to simulate nearly all human hand movements.

Due to the moving parts with a total of nine drives, various gripping operations can be executed with high sensitivity. Elastic gripping surfaces ensure a reliable grip on objects.

In addition to new dimensions in gripping and manipulation tasks, SCHUNK is defining the possibility of human/robot communication by gestures with the 5-finger hand.

Please visit us at N0512 in TWTC Nangang Exhibition Hall for an informative introduction to the most innovative gripper in the market -SCHUNK 5-Fingerhand SVH. ■



Hand in hand with the technology of tomorrow: German Chancellor Angela Merkel experiences the possibilities of the SCHUNK 5-finger grippers at the Hannover Messe.

# ASIA'S ONLY PROFESSIONAL 5-AXIS MACHINE CENTER MANUFACTURER



KEN CNC is the only company that specializes in 5 axis gantry machine centers for the aerospace and automotive industries.

We integrate European key components with Taiwanese professional team, to satisfy the needs of following industries

-  **Aircraft Industry**
-  **Automotive Industry**
-  **General Machining Industry**

**HIGH SPEED**      **FEEDRATE:60 M/MIN**      **HIGH TORQUE**      **MAX. TORQUE : 1,200 NM**



## Focus 5

### 5-Axis Double Column Machine Center

- High rigidity one piece column and crossbeam structure
- XY - axis linear motor drive
- Direct-drive motor two-axis milling head



## SABER

### Double Column 5-Axis Machining Center

- European high torque 2-axis milling head with high torque spindle
- High rigidity one-piece base and column
- Z-axis movement by two high rigidity box-way
- Suitable for high titanium materials of aerospace industry



## COMPACT B

### Gantry Type High Speed 5-axis Machine Center

- Gantry type
- Box-in-Box symmetrical design
- Column and base one piece design
- XY - axis linear motor drive
- Direct-drive motor two-axis milling head



## TITAN

### Double Column 5-Axis Machining Center

- Z-axis moving crossbeam
- One-piece h-type column structure
- European imported high torque 2 axis milling head
- Heavy duty roller type linear guideway
- Suitable for high titanium materials of aerospace industry



## Linmax B

### Gantry Type High Speed 5-axis Machine Center

- Gantry type
- Box-in-Box symmetrical design
- Column one piece design
- XY - axis linear motor drive
- Direct-drive motor two-axis milling head
- Modular design milling head



## RHINO

### Horizontal 5-Axis Machining Center

- Cross beam moves up and down, milling optimal rigidity
- One piece H type column
- Hydrostatic rotary table
- Short throat depth tilting milling head



## KEN: The expert in high speed 5-axis machining center

The main focus of KEN at TIMTOS 2019 is in promoting the third generation (Compact B series) gantry type high speed five-axis machining center. The main features are consisted of three improved key elements: rigidity, precision, and efficiency. These features are mainly for improving the overall performance of the third generation Compact B gantry type high speed 5-axis machine center. Through the following design, the machine is aimed to achieve ever-faster and more stable performance. First, the X/Y axis linear motor drive increases stability in machining. Secondly, the gantry type five-axis machining center has a one piece design in column and base – which improves stability and rigidity; third, the box in box symmetrical design reduced the effect brought about by temperature changes, where accuracy is improved. Equipped with German linear motor drive, makes the components free of wear increase accuracy, as well as the life span of key components. In addition, KEN develops 2-axis milling head with their Italy partners, which is the core mechanism for 5-axis machining center to perform in high quality.

KEN has always persisted in positioning itself as the high speed 5-axis manufacturer since the beginning of its

establishment. KEN concentrates on supplying aerospace and automotive mold-die industries. General Manager Luke Chang said that in the past 10 years, the rapid development of KEN in mainland China was due to its clear positioning and its unique technology that no substitutes could be found. General Manager Luke Chang also shared several milestones KEN reached in 2018. Last year's production on five-axis machine tools exceeded 70 units, and the company successfully exported to Germany. "This scale of production capacity is already comparable to European brands; moreover, in the past few years only very little amount of Asian brands have been able to successfully export to Germany. Thus, this is an achievement worth celebrating.

Speaking of the goal in the year 2020, General Manager Luke Chang shared that KEN has set the production target to reach 100 units. If this target is reached, then KEN has a very high opportunity in becoming the world's top five five-axis machine tool supplier. Apart from technology being the foundation for expanding production capacity and business scale for KEN, recently the company will enhance the field of customer service. They have established customer support centers



Exclusive interview with Luke Chang General Manager, KEN ICHI MACHINE CO., LTD.

in China, where the service team is capable for maintenance and fixing. In addition, KEN has the ability to manufacture and fix direct-drive motor 2 axis milling head, which is rare for Asian 5-axis manufacturer. This would be extremely helpful in reducing the limits of time and distance between European 2-axis milling head provider and Asian clients. Finally, KEN will establish an 'application team' that assists clients to jump right into manufacturing and applying the products to the right industries. With

these outstanding and creative services, KEN is ready to stride into the next 10 year anniversary with its practical techniques, strong 5-axis machine and edge-cutting technologies.

**KEN ICHI MACHINE CO., LTD.**

Tel: +886-4-2565-3080

Fax: +886-4-2565-3090

E-mail: [info@kencnc.com](mailto:info@kencnc.com)

Website: [www.kencnc.com](http://www.kencnc.com)

**Booth No.: I0616**

## POSA: Wireless transmitted tool holder to embrace 5G network

POSA has two major exhibit themes at TIMTOS 2019. The first will be the revealing of "intelligent spindle diagnosis system". This particular theme will integrate real-time connection – and display the information on spindle operation from POSA's clients on their booths. The second theme is POSA's latest innovation: 'Wireless Transmission Ultrasonic tool holder'. This particular tool holder is designed with POSA's own technology, with patents filed on the transmission structure, in cooperation with the wireless transmission technology that Taiwan's research institution has developed for electric cars. The combination has created a high speed transmission efficiency for ultrasonic tool holders, in comparison to the method of using wired transmission in the past. POSA's wireless transmission technology has presented the industry greater processing efficiency and quality. As a result, the Wireless Transmission Ultrasonic tool holder has also won the 2019 Taiwan Excellence Award. It is not only the first in Taiwan's spindle industry, but also the only award-winning company and product.

The wireless transmission technology facilitated by POSA's Wireless Transmitted Ultrasonic tool holder can effectively reduce the problem of ultrasonic blade heating. Furthermore, the speed can be increased from a traditional 8000RPM to 24000RPM.

Under the structure of POSA's patented wireless transmission, the speed of ultrasonic transmission efficiency can be increased from 23% to 46%, efficiency and accuracy greatly improved.

Compared with 2017, POSA has also shown steady growth in 2018. In 2019, commercial 5G network signals will begin to be introduced globally. The application is not limited to mobile phones, but a great variety of connected home appliances or electronic devices. A great amount of electromagnetic signals will be transmitted. Yet under the current condition of using metal as the main material for mobile phone cases that would affect the transmission, the industry would bound to find new materials in substitution to metal. It seems that the high-end mobile phone market will be dominated by sapphire and ceramic materials. They are particularly hard and brittle material that is difficult to process. It is easy to cause tool wear and breakage during processing. Consequently, ultrasonic machining becomes an outstanding solution to shatter the structure of the workpiece for further machining, to reach precision and extend tool life.

POSA has therefore developed the wireless transmitted Ultrasonic tool holder. In addition to the ultrasonic instruments of the hardware, special material tools,



ultrasonic oscillators, POSA also provides customers with a variety of different materials in assisting customers to build comprehensive ultrasonic machining solutions.

In the past, "Intelligent Manufacturing" or "Industry 4.0" mostly are considered to be the issues for machine tool builders. And a great amount of so-called "smart spindles" builders in Taiwan often insert sensors in the spindles to fulfill the request from equipment manufacturers on receiving signal of spindles. POSA has never been satisfied with this situation and has been constantly finding solutions to assist Taiwan industry be engaged in intelligent manufacturing.

After observation, feedbacks and discussion with our users and counterparts, we have identify that the problem lies in the insufficiency of resources for mid-small scale manufacturers. Many SMEs do have the motivation to invest in smart manufacturing but often limited by lack of research ability. As over 90% of Taiwan's industrial structure is dominated by small and medium-sized enterprises, this issue

is imminent, and it could make a huge difference if POSA could help them enter intelligent manufacturing. This is the background of POSA on deciding to invest resources to develop the "smart spindle diagnostic system". One advantage of POSA is out mass production on spindles - more than 20,000 to 30,000 spindles per year. We could draw the real data from these spindles and build a database particularly for spindle machining. Along with university research teams, POSA uses Cloud Technology to send the spindle data back to the server for "big data analysis". Customers can then use mobile APP to real-time monitoring of the data on the spindle. The next step is to develop advanced inspection system that prevents damage and optimize service. Through the combination of hardware and software, we will help customers build their intelligent factory.

**POSA MACHINERY CO., LTD.**

Tel: +886-4-2213-5988

Email: [posa.posa@msa.hinet.net](mailto:posa.posa@msa.hinet.net)

Website: [www.posa-spindle.com](http://www.posa-spindle.com)

**Booth No.: Q0502**



## Every Spindle is tested up to **72 Hours**

Using state of the art instruments . Precision assembly techniques must pass High-Reliability test. The most advanced machinery finishing equipment feature-ing the best of western technology and own decades of finishing and manufacturing experience.



## CUSTOMIZATION

Help you improve the performance of processing equipment best companion.

## SPINDLES REPAIR

Provide a variety of domestic and foreign machine tool spindle service.



CNC Machining  
Center Spindle



CNC Turning  
Center Spindle



CNC Grinding  
Spindle



Special Machine  
Spindle



**KENTURN**

**ECIO**

ECIO易上手 好用好上手  
The ideal option for efficient cutting

**T** +886-4-7910-688

**F** +886-4-7910-272

**E** [ecio@kenturn.com.tw](mailto:ecio@kenturn.com.tw)

**W** [www.kenturn.com.tw](http://www.kenturn.com.tw)

難切削材刀具／客製特殊刀具



### Kenturn Nano. Tec. Co., Ltd

☎ +886-4-791-0271    📠 +886-4-791-0272

✉ [cnc-spindle@kenturn.com.tw](mailto:cnc-spindle@kenturn.com.tw)

🌐 [www.kenturn.com.tw](http://www.kenturn.com.tw)

📍 16E.7Rd., Chang Bin Ind. Park, Shian shi, 50741 Chang Hua, Taiwan



## YCM: 65 years mechanical excellence thrives through the new era

The senior machine tool builder YCM will meet the industry again at TIMTOS 2019. YCM has established its superiority in the field of machine tool with high precision, rigidity, and sustainability since 1954. Presently the company diversifies their R&D technology into ever-innovative production systems while concentrating on the traditional heritage of machining technique – practicing from the in-house foundry to spindle production, strict quality assurance and metal scraping craftsmanship.

At TIMTOS 2019, YCM will showcase NFX800B-MPS multi-axis flexible manufacturing system in response to the industrial revolution in manufacturing industry. The all-new NFX800B-MPS with smart automation, smart machine and smart management, enabling the shop floor to be highly intelligent. NFX800B-MPS with a number of patents and advanced technologies is particularly suited to efficient manufacture of geometrically complex and high-accuracy parts in aerospace industry. In order to achieve the highest productivity and efficiency, it features 5-axis machining in one clamping in a smaller footprint. Also, it provides an ultimate solution against thermal issue to maintain high stability during long-time machining. To bring more competitive advantages along the entire value chain, there are 3 elements of smart factory applied in NFX800B-MPS. First of all, the most vexing problems will be solved with smart automation as its 5-axis rotary table equipped with accurate jaw system. It allows multiple pallets change that enhances the flexibility in automated module applications. Secondly, it is identified as a smart machine that the vital sensors are strategically placed throughout the machine. After the big data analytics and cloud based real-time monitoring, the intelligent software from iPros MX and advanced hardware will work in unison. Furthermore, the plants manager



and owners can smartly manage her shop as applying YCM's latest IoT solution iDirect. This system will connect all your equipment and provide real-time analysis of live data from the production environment. And you can easily track production status, manage factory utilization and monitor your Overall Equipment Effectiveness (OEE). NFX800B-MPS, with sophisticated structure design and smart manufacturing solutions, achieves the ultimate in machining accuracy, performance and operating convenience. This is undoubtedly the best value-added product to your business.

### i-Direct as the strong backbone for efficient and smart production

YCM's exhibition theme at TIMTOS echoes loudly with the organizer's topic "The Sharpest Edge for Industry". YCM will present the latest IoT solution named i-Direct which is given an easy way to connect all your equipment, including CNC controller, machine types and manually operated equipment. It provides real-time

analysis of live data from the production environment, enabling plants manager and owners to manage her shop with ease. Using this IoT system, you can easily track production status, manage factory utilization and monitor your Overall Equipment Effectiveness (OEE). With big data and cloud computing technology, i-Direct is capable of identifying the bottlenecks of your production process that you can react quickly to problems and continuously improve productivity. The IoT platform i-Direct will give the visibility you need to be profitable.

### An optimized machining future with YCM

YCM has been devoted in assisting customer the necessary tool to enter the next level of machining, and be part of the so-called Industry 4.0. There are two areas that YCM focuses on. First, i-Direct IoT platform allows customer to monitor and manage their shop in real time. Secondly, YCM continues to develop intelligent function in their machines to optimize the

performance and life of the equipment. Intelligent spindles and drive systems automatically enhance machining time, while minimizing machining vibration to achieve best surface finish and tool life. The intelligent functions will also monitor the health of your equipment and predict future failure of spindle and drive system that allows scheduled maintenance to prevent sudden failure of your equipment that disrupts you production. "Sustainable development and becoming one of the top value machine tool manufacturers in the world" has been the vision of YCM. YCM will offer automated solutions as well as jig and fixture design. With the continuing development of our i-Direct IoT platform, YCM will keep pursuing intelligent production systems and software for customer to manage their shop with ease. YCM will also continue to develop multi-axis and multi-functional machining centers that will drastically improve customer productivity with smaller floor space that allows customers to make more with less.

TIMTOS is one of the world's most international metalworking trade show, and it provides a networking platform for global buyers and traders. This is the reason why YCM sees it as an important show. Through the participation in TIMTOS, YCM will showcase their transformation into a smart manufacturing company, and how this could to benefit the users globally. Finally, it is in the hope of the company to market YCM brand around the world and promote its innovative technology in the field of machinery and ensure that 65 years of mechanical excellence lingers on.

#### YCM

Tel: +886-4-2562-3211

Email: sales@YCMCNC.com

Website: www.YCMCNC.com

Booth No.: J0618

## SIGMA: Cater to the needs of customers

In TIMTOS 2019, SIGMA exhibited its new large-scale five-axes machine. This machine is mainly used in surface machining or special angle machining of some difficult-to-cut materials. Unlike the previous products, the Z-axis and Y-axis of this new product is specially designed for suppressing cutting vibration, better cutting surfaces and faster cutting speeds are achieved under the conditions.

In 2018, SIGMA achieved a double growth. Mr. Humor Chuang, President of SIGMA said: "Quality is essential to the company's future survival, our aim is to satisfy the customer's needs, so we

must know the trend of global industrial development, and then choose a product that we believe can compete with our counterparts." In the future, SIGMA will continue to focus on areas such as aerospace and automotive.

As for the topic of industry 4.0, Mr. Humor also said that this is indeed a trend of the times. Humanize, smart, energy-saving manufacturing methods and customization are truly the characteristics of this era. Products must be competitive and be recognized by customers. "I think that any function of the product is originated from the actual needs of the customer. At present,

in order to keep pace with other competitors, every company should participate in the process of smart manufacturing."

**SIGMA CNC Technology Machinery Co., Ltd.**

Tel: +886-4-2562-8000

E-mail: sigma.cnc@msa.hinet.net

Website: www.sigmacnc.com.tw

**Booth No.: TAIPEI NANGANG**

**Exhibition Center, Hall 2, P0814**

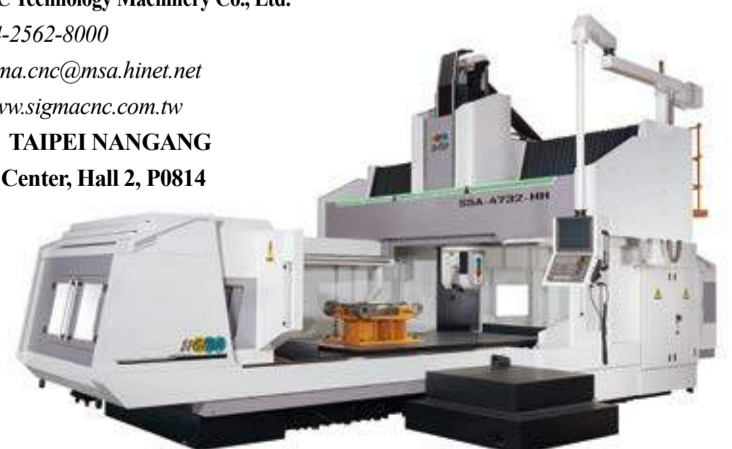

# Machining concepts for today's future mobility

In view of the expected dynamic development of e-mobility, the automotive-related machine tool industry is confronted by challenges in terms of machine concepts and production processes, which need to be solved using innovative approaches.



Efficiently geared by using the power skiving technology

**B**ecause in order to achieve the required drive torque, gearboxes in electric vehicles require a very high gear transmission ratio.

The accompanying engine speed rates of up to 17,000 rpm have a negative impact on noise sensitivity and wear behaviour. For example, noises which occur near the powertrain are perceived much more clearly due to the lack of background noise associated with a combustion engine. To solve these problems, enormous requirements are made with regard to the balance quality of moving components in the powertrain of electric vehicles, which results in tighter shape and position tolerances and thus the necessity of machining the corresponding components even more precisely.

## Soft machining

Taking these quality premises into particular account, Werkzeugmaschinenbau Ziegenhain (WMZ) has realised a pioneering integrated production solution for the complete machining of hollow shafts for electric motors – from the raw to the finished part – for a renowned German automotive supplier, working in cooperation with its DVS sister companies BUDERUS Schleiftechnik, PRÄWEMA Antriebstechnik and DVS Production.

For this purpose, WMZ has developed an efficient complete machining center for the holistic soft machining of hollow shafts, which is then followed by hard-fine machining processes using a machine from the DVS UGrind series designed by BUDERUS Schleiftechnik and a gearing

honing machine from PRÄWEMA. The series production of the first shaft type is currently in the ramp-up phase at DVS Production GmbH in Krauthausen in Thuringia/Germany. The design space available is extremely limited in the electric drives segment, so that motor and gearbox almost merge into one unit by means of function integration. For this reason, the drive gearing is integrated into the hollow shaft of the motor. The electric motor rotor is located between the bearing seats (Figure 1: reference A and B).

In addition, corresponding motor shafts are characterised by a through hole which both serves to reduce the mass inertia and makes the power take-off possible on the opposite drive side. A hardening processing is also necessary due to the running gears. The critical manufacturing tolerances for hollow shaft machining resulting from this, shown in Figure 1, are the tight run-out tolerances of the shaft bore and gearing to the bearing seats and the low tool run-out during gear cutting caused by the design space. With a view to the required manufacturing quality and cycle time of the subsequent hard-fine machining, the soft machining process must produce the complete inner contour, several external surfaces and grooves, the gear cutting as well as the bearing and rotor seats already to the finished dimension or with only a very small allowance. Otherwise the final shape and position tolerances will not be achieved.

## Power skiving method

In order to fulfil all requirements and guarantee maximum process and cost

efficiency, WMZ has created a multi-technology manufacturing solution that combines turning, milling and drilling operations as well as gear cutting using the highly productive power skiving method. In order to minimise reclamping errors which have a negative impact on manufacturing quality, the option of distributing the machining steps to several individual machines was excluded from the very beginning. As a side effect, retooling, transport and waiting times – and thus the overall processing times – can also be reduced. Nevertheless, the complex variety of technologies used makes the fulfilment of various attributes of a machining center absolutely crucial: while turning and milling work needs maximum flexibility and dynamism, both precision drilling and power skiving require maximum rigidity and geometric accuracy.

Moreover, the drilling of bore holes to the required depth and tolerance makes enormous pressures and volumes necessary with regard to the cooling lubricant system in order to facilitate the fast and safe clearance of chips. For this reason, the successful WMZ H200 was chosen as an adequate machine base, since its modular design permits the flexible implementation of a wide range of different machining operations. Numerous series applications based on this machine concept, which stands out on account of its flatbed construction, confirm its remarkable dynamic and thermal rigidity.

Whereas the turning and milling requirements were able to be realised using tried-and-trusted components, the WMZ design engineers – in close cooperation with the DVS power skiving specialists PITTNER T&S and PRÄWEMA – came up with an innovative combined power skiving module for the high-precision

manufacturing of the running gears and the shaft bore. With the development of this module, that can be adapted flexibly to different gearing geometries, WMZ is expanding its range in the field of the complete machining shaft-shaped components and can fall back on this development for applications down the line.

## Precision chuck prevents reclamping faults

The complete soft machining of the hollow shafts is carried out completely automatically by an H200 machine and only two clamping processes. A tried-and-trusted WMZ loading module guarantees automated loading and unloading as well as the onward transport of the hollow shafts from OP10 to OP20. Thanks to the optimum interaction between the machine's internal automation and the specially developed precision chuck made by the DVS partner SWS Spannwerkzeuge GmbH, reclamping faults are negligible and thus have no negative impact on the manufacturing quality. The subsequent hard-fine machining can then be carried out using optimally pre-machined workpieces.

After the manufacturing process has been completed, the workpieces are marked with a dot matrix code by an engraving laser station integrated in the finished part conveyor, enabling clear part identification and traceability. Within an extremely short cycle time, a simple cut off piece is turned cost- and process-efficiently into a hollow shaft with more than 150 complex characteristics and meets the most stringent of precision requirements – exactly as required for the components of the increasingly important electric drive. ■

Source: *Int'l Metalworking News for Asia*

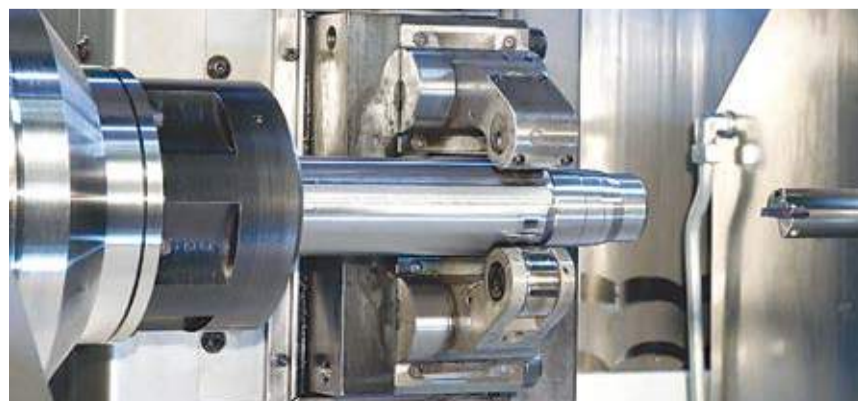



# 盈錫積極邁入智慧製造 生產模式滿足客戶少量多樣的需求

盈錫為國內知名的工具機零配件精密螺帽製造商，全力建構智慧化工廠，讓產品更加滿足客戶需求。



I262262  
專利號 I385314  
I427279



YS

YSPL

歐美日等工具機大廠 ▶ 精密螺帽及精密零件主要供應商

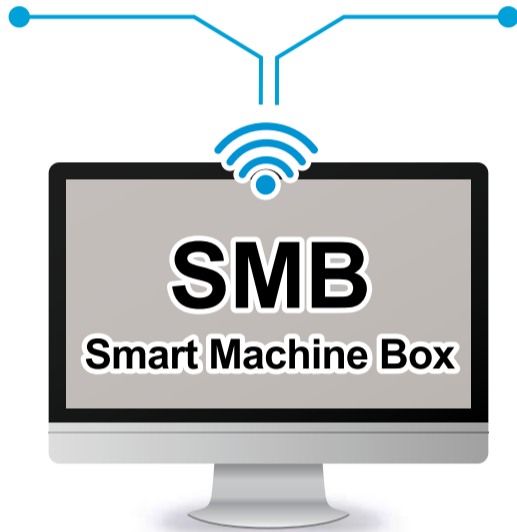

**戰情室**  
電子互動資訊看板

**Robot + AGV**  
智能化機電整合應用

**MES**

**ERP**

**AI** 智慧圖面報價  
輔助系統

**TIMTOS** 南港2館  
2019 March 4-9  
第27屆台北國際工具機展覽會  
R0814



盈錫精密工業股份有限公司 YINSH PRECISION INDUSTRIAL CO., LTD.

www.yinsh.com  
www.yinsh.hdv.tw

電話：+886-4-2244-7899  
傳真：+886-4-2245-2402

信箱：service@yinsh.com  
地址：台灣台中市北屯區崇德六路一段31巷26號



# 2019 RINGIER MANUFACTURING AND PROCESSING INDUSTRY SUMMIT

## CHINA MARKET

- ◆ High-efficiency Machining Intelligent Automation Summit 2019 | 06-07 MAR, Chongqing
- ◆ Foshan High-efficiency Processing Manufacturing Technology Summit 2019 | 11 APR, Foshan
- ◆ High-efficiency Machining Conference 2019 - Beijing | 14-15 APR, Beijing
- ◆ Difficult Processing Materials High-efficiency Processing Manufacturing Technology Forum 2019 (customized Conference) | 15 APR, Beijing
- ◆ High-efficiency Machining Conference 2019 - Nanjing | 22 MAY, Nanjing
- ◆ The Mold Technology (Ningbo) Forum 2019 | 30 MAY, Shanghai
- ◆ 2019 Global Laser Processing Technology Summit | 06 JUN, Shanghai
- ◆ The 6th Mould High Efficiency Manufacturing Technology Summit 2019(semi-customized Conference) | 10-11 JUN, Shanghai
- ◆ Global Smart Factory Summit 2019 | 28 JUN, Shanghai
- ◆ Implantable & Interventional Medical Device Manufacturing & Technology Conference 2019 | 8-9, AUG, Suzhou
- ◆ The 2nd New Energy Vehicle Manufacturing Conference 2019 | 04-05 SEP, Shanghai
- ◆ China International Internal Combustion Engine Advanced Manufacturing Technology Summit 2019 | 06 SEP, Suzhou
- ◆ China International Internal Combustion Engine Advanced Manufacturing Technology Summit 2019 | 17-18, OCT, Suzhou
- ◆ 2019 China Intelligent Laser Manufacturing Technology Forum | 24 OCT, Shenzhen



## S.E. ASIA MARKET

- ◆ ASEAN Automotive & Motorcycle Parts Manufacturing Summit | 02-03 APR, Hanoi Vietnam
- ◆ India Automotive & Motorcycle Parts Manufacturing Summit | 16-17 JUL, Pune India
- ◆ ASIA Plastics Processing Technology and Innovative Materials Summit 2019 | 29-30 AUG, Jakarta Indonesia
- ◆ ASEAN Automotive & Motorcycle Parts Manufacturing Summit | 05-06 NOV, Jakarta Indonesia



Registration, sponsorship consultation and details Information request, please scan the QR code

 **Ringier Events**  
Connecting industry through information exchange!

[www.ringierevents.com](http://www.ringierevents.com)



# 緊盯著您的刀具

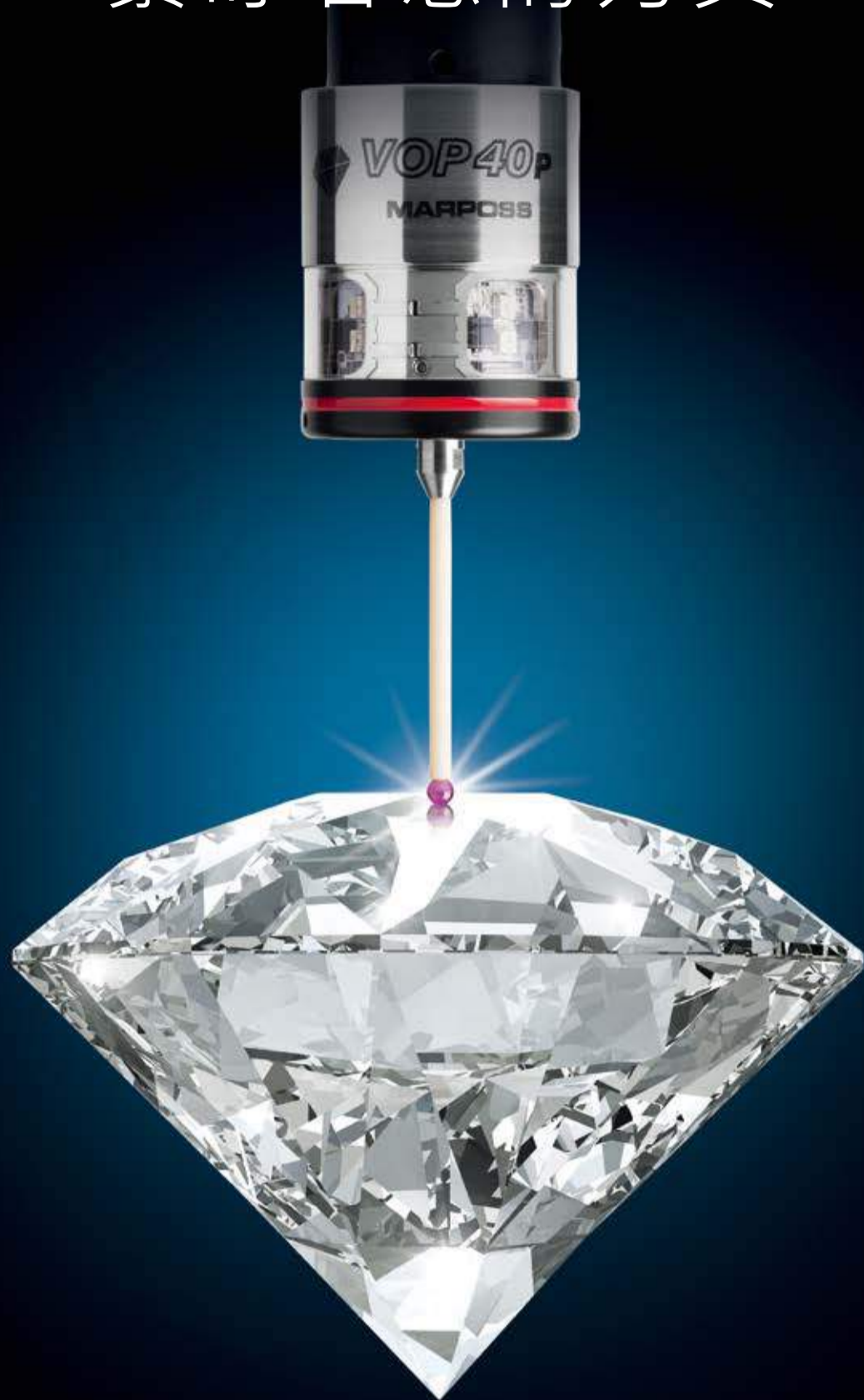

**mida** ULTRA PRECISION PROBING

當今日對於精確的需求已達到極限之時, **Marposs Diamond System** 創新突破重新定義機上工件量測規則。

**VOP 40 Diamond** 測頭能夠給予最優的檢測功能, 即使是極其複雜的工件或 3D 表面, 甚至在最小型的機台, 也可確保精確的高品質與減少不良品的產生。



**MARPOSS**

您全球的合作夥伴

[www.marposs.com](http://www.marposs.com)

**馬波斯精密股份有限公司**

台中市南區復興路二段120-3號4樓

Tel. +886-4-2262-2340 Fax. +886-4-2262-2402

## Exhibit Highlights

### H-360HB Fully-Automatic Column Type Bandsaw

Everising bandsaws, always have the most reliable quality and feature



the maximum stability and trouble free operation. Everising model H-360HB fully-automatic column type bandsaw provides not only united and heavy-duty construction but also durability of production. Heavy-duty cast iron head and wheels designing capable to cut maximum 360mm always gives you good performance cutting. P.L.C. control for all electrical and hydraulic function allows you to have a consistent productive machine. Vise clamping system, saw frame lifting, down feed, and nesting fixture all control via a powerful hydraulic system. The blades are guided by tungsten carbide inserts and roller bearing offering rigidity and reducing vibration. Variable blade speed control by inverter and adjustable feed rate and feed pressure allowing the operators always have a perfect cut on different material and longer blade life. H-360HB model is one of the best saw in the market for the small or large shop.

Everising's heavy duty bandsaws are built to the highest standards in the market. The machines' productivity and cutting performance are tremendous and always are your number one choice.

#### EVERISING MACHINE CO.

Tel: +886-4-2350-5300

Fax: +886-4-2350-5420

E-mail: [evrs@everising.com.tw](mailto:evrs@everising.com.tw)

Website: [www.everising.com](http://www.everising.com)

Booth No.: I0408

### Turning & Milling Complex Type CNC Lathe

The bar capacity for HCP-42 is Ø42 mm, and standard is with A2-5 spindle. It's optional to choose 42# collet or 6" 3-jaw hydraulic chuck. Adopt the full roller linear guideway configure, wide rail design, and with high rigidity construction which provide the best machining performance condition for customer.

Besides, HCP-42 has various optional accessories, such as hydraulic or servo turret,



single shaft side milling device, Y-axis 4 shafts side milling device, 3 shafts drilling or tapping device and polygon milling devices, etc. As C-axis function (optional), it can be applied on the control of random spindle positioning angle and (workpiece turning) profile. Therefore, processing side/end milling, eccentric drilling and outer diameter turning are available. It can be configured by the processing demand of customers.

#### Jarng Yeong Enterprise CO., LTD.

Tel: +886-4-2615-2157

Fax: +886-4-2615-2161

E-mail: [greenway@cnc-lathe.com](mailto:greenway@cnc-lathe.com)

Website: [www.cnc-lathe.com](http://www.cnc-lathe.com)

Booth No.: L0326

### Twin Spindle and Twin Turret Complex Turning and Milling Machine

The new generation of twin-spindle turning and milling machine adopts horizontal bed surface and 45-degree column. On the basis of high-rigidity



structure, the left and right turrets can be freely equipped with Y-axis milling cutter function, with a maximum of 30 tool positions. It can be combined with a built-in robot or a door-type robot to achieve a machine that is a production line. The customer's smallest footprint and most economical, production is beyond the imagination of the heart-shaped processing benefits.

#### Taiwan Takisawa Technology Co., Ltd.

Tel: 886-3-4643-166

Fax: 886-3-4643-674

E-mail: [richard.su@takisawa.com.tw](mailto:richard.su@takisawa.com.tw)

Website: [www.takisawa.com.tw](http://www.takisawa.com.tw)

Booth No.: K0108 Hall 1

### 5-Axis Vertical Machining Center UB-660

1. T-shaped ultra-high rigidity base, combined with mobile column structure, excellent dynamic performance and high precision machining in large and heavy workpieces

2. The Swiveling type (B-axis spindle) combines with the horizontal rotary table (C-axis), and the workpiece has no rollover effect, which ensures the precision and quality of the workpiece.

3. High torque built-in type spindle, 12000rpm, torque 88.3Nm, power 37Kw

4. Suitable for long and complex workpieces with maximize processing efficiency and minimum space.

5. Combined typed work table helps



to complete the setup quickly with only one clamp, which improves efficiency and saves processing time.

6. The oil cooling system uses variable-frequency type liquid cooler to provide the spindle/ Swiveling Spindle head/ turning table to maintain stable operation at the optimum temperature, showing high efficiency and high precision machining characteristics.

7. 5-Axis vertical machining center with high rigidity and high precision

#### FAIR FRIEND ENT. CO., LTD.

Tel: +886-4-2359-4075

Fax: +886-4-2359-4873

E-mail: [sales@feeler.com](mailto:sales@feeler.com)

Website: [www.feeler.com](http://www.feeler.com)

Booth No.: J0330

### LICO: Multi-tasking LNDD machines

LICO Machinery Co. specializes in CNC single-spindle screw machines that blend the speed of screw machines with the precision and versatility of CNC lathes. With 38 years in cam-type automatics and 25 years in CNC Multi-Slides Turn-Mill Centers, LICO has teamed up with many experienced machinery dealers throughout the world to ensure good services.



The LICO LNT series of CNC screw machines feature various levels of technology enabling you to match the right machine to the right part. Built on a rugged base, these machines employ up to four 2-axis cross slides arrayed around the spindle. All 4 slides and the turret are capable of overlapping with each other [Parallel Machining] or [Multi-tasking]. The slides are dovetail and gib design, giving you the rigidity to make use of form tools to maximize material removal rates without chatter. The machines include a 2-axis eight position turret with live-tooling on every position. These machines are fixed headstock machines, so no special material or learning sliding-headstock technology is required. Spindle bores range from 36mm through 65mm. On most parts, the LNT machines will outperform any Swiss type machines up to 7-axis. Our 3-turret version, LNTS-T3, even outperforms competitions

in Germany to win orders.

The latest machine model is the LNDD machines, which adds 2-3 cross slides to a traditional Twin-spindle Single-turret machine. The turret has a True-Y axis (+/-55mm) that allows for multiple tools at each turret position for working on both spindles. This machine also comes in larger spindle bores, 80mm and 100 mm.

Visit LICO in TIMTOS 2019 at booth number N-0330.

#### LICO Machinery Co., Ltd.

Tel: +886-4-2563-0950

E-mail: [sales@licomachinery.com](mailto:sales@licomachinery.com)

Website: [www.licomachinery.com](http://www.licomachinery.com)

Booth No.: N-0330

### Quick Die Change System

Forwell Quick Die Change System includes die clamps, die lifters, die arms,



control box and power units. Reducing die change time, saving labor costs and increasing safety are the advantages.

The Quick die change system is controlled by hydraulic. It's easy and safe comparing traditional way. Although power is off, the system can keep working for 48 hours. Not only secure workers but also keep machine on. Forwell is the one of well-known manufacture in quick die change system. High quality and best service are our slogan. We assure Forwell is your best choice in the world.

#### Forwell Precision Machinery Co., Ltd.

Tel: +886-4-8345196

Fax: +886-4-8345197

E-mail: [forwell@forwell.com](mailto:forwell@forwell.com)

Website: [www.forwell.com](http://www.forwell.com)

Booth No.: D0530

### Uni Mag: Rare Earth Magnetic Separator

The magnetic force is up to 5000 gauss, makes the filtration efficiency up to 10µ! No consumption at all. Applicable to weakly ferrous metal, oil-based or water-based coolant.

#### Uni Magnetic Industrial Company

Tel: +886-4-7810-900

Fax: +886-4-7810-901

E-mail: [matildalin@unimag.com.tw](mailto:matildalin@unimag.com.tw)

Website: <http://www.unimag.com.tw>

Booth No.: R0908



Exhibit Highlights

**YCM: NFX800B-MPS Multi-axis Flexible Manufacturing System**

In response to the industrial revolution in manufacturing industry, YCM launches all-new NFX800B-MPS multi-axis flexible manufacturing system with smart automation, smart machine and smart management, enabling the shop floor to be highly intelligent. NFX800B-MPS with a number of patents and advanced technologies is particularly suited to efficient manufacture of geometrically complex and high-accuracy parts in aerospace industry. To achieve highest productivity and efficiency, it features 5-axis machining in one clamping in a smaller footprint. Also, it provides an ultimate solution against thermal issue to maintain high stability during long-time machining. To bring more competitive advantages along the entire value chain, there are 3 elements of smart factory applied in NFX800B-MPS. First of all, the most vexing problems will be solved with smart automation as its 5-axis rotary table equipped with accurate jaw system. It allows multiple pallets change that enhances the flexibility in automated module applications. Secondly, it is identified as a smart machine that the vital sensors are strategically placed throughout the machine. After the big data analytics and cloud based real-time monitoring, the intelligent software from iPros MX and advanced hardware will work in unison. Furthermore, the plants manager and owners can smartly manage her shop as applying YCM's latest IoT solution i-Direct. This system will connect all your equipment and provide real-time analysis of live data from the production environment. And you can easily track production status, manage factory utilization and monitor your Overall Equipment Effectiveness (OEE). NFX800B-MPS, with sophisticated structure design and smart manufacturing solutions, achieves the ultimate in machining accuracy, performance and operating convenience. This is undoubtedly the best value-added product to your business.

**Yeong Chin Machinery Industries Co., Ltd.**  
 Tel: +886-4-2562-3211  
 Fax: +886-4-2562-6479  
 Email: sales@YCMCNC.com  
 Website: www.YCMCNC.com  
**Booth No.: J0618**



**B-axis Spindle & Swivel Head, SHD-40**

Posa Machinery is a professional spindle manufacturer which owns complete product range. Product range includes lathe spindles, machining center spindles, grinder spindles, and boring machine spindles. In addition, due to the global clients' needs of energy saving, high quality and high efficiency, Posa Machinery developed B-axis Spindle & Swivel Head, SHD-40. Integrated design allows smaller spindle with low vibration and noise and easy maintenance.

With the concept of intelligent spindle, built-in spindles of Posa Machinery detect

inner temperature and vibration which may affect the spindle accuracy via various built-in sensors. Because of the detect sensors, the efficiency and lifetime of spindles are improved.

Posa Machinery was established in 1994. Since our founding, "Sincere Business Management, Always Loyal to Customers" has been at the core of Posa's business philosophy. We appreciate the supports from international and domestic clients and partners. This enables us to trace the development of Taiwan machine tool industry, continuously grow up and become the leading company of Taiwan spindle manufacturers. We will attend TIMTOS



from March 4th to 9th in 2019. Welcome to visit our booth. Our booth number is Q0502.  
 POSA MACHINERY CO., LTD.  
 Tel: +886-4-2213-5988  
 Fax: +886-4-2213-5996  
 E-mail: posa.posa@msa.hinet.net  
 Website: www.posa-spindle.com  
**Booth No.: Q0502**



[www.posa-spindle.com](http://www.posa-spindle.com)



**Pioneer of Spindle Area**  
**26 Years Advancing Technology**  
**The best manufacturing option for Industry 4.0**





**It is measured by a dial gauge  $\leq 0.002\text{mm}$ ,  
 Test bar 300mm  $\leq 0.005\text{mm}$**





2019/3/4-9  
 27<sup>th</sup> Taipei Int'l Machine Tool Show  
**Booth No. Q0502**

**POSA MACHINERY CO., LTD.**  
**TEL: 886-4-2213-5988 Email: posa.posa@msa.hinet.net**



spindleposa



## Exhibit Highlights

### Precision Locknuts

YINSH has specialized in developing and producing Precision Locknuts for 29 years. In order to meet the needs of even more customers, we began to invest in high-end machines and started to provide a "Precision Part Manufacturing Service" three years ago. Besides, we launched a brand-new product with our Axial Force Sensor which has been well-received in the market.



**YINSH PRECISION IND. CO., LTD.**

Tel: +886-4-2244-7899  
 Fax: +886-4-2245-2402  
 E-mail: [service@yinsh.com](mailto:service@yinsh.com)  
 Website: [www.yinsh.com](http://www.yinsh.com)  
 Booth No.: R0814

### Built-in motor spindle: MVB1318A

Built-in motor spindle: MVB1318A Kenturn designed spindle with OTT made HSK-A63 drawbar system, can completely cool down spindle shaft bore temperature, as well control thermal deformation. Besides,



the oil-air lubricated bearings can stand long-term cutting operation. The spindle's motor power is up to 25KW, speed 18000 RPM, using dual contact tool holder, can be used in vertical machining centers and medium gantry machine. Optional accessory: Intelligent sensor, that matches with watchdog agent toolbox, to monitoring spindle situation, to offer best cutting suggestion.

**Kenturn Nano. Tec. Co., Ltd.**

Tel: +886-4-7910-271  
 Fax: +886-4-7910-272  
 E-mail: [cnc-spindle@kenturn.com.tw](mailto:cnc-spindle@kenturn.com.tw)  
 Website: [www.kenturn.com.tw](http://www.kenturn.com.tw)  
 Booth No.: Q0804

### GT-ML800 5-Axis Mill-Turn machining center

This multifunctional mill-turn machine is built from the rigid integrated double column structure; a high-speed mill-turn spindle and 5-axis simulation function enable diverse machining operations for

multi-side and complicated shape parts. One setup part clamping, operated from roughing to finishing contributes the best production efficiency. This machine can be connected with robot arm and automatic material handling system for a smart and high efficiency production management.



**Gentiger Machinery Industrial Co., Ltd.**

Tel: +886-4-2683-6919  
 Fax: +886-4-2683-9900  
 Email: [GT@gentiger.com.tw](mailto:GT@gentiger.com.tw)  
 Website: [www.gentiger.com.tw](http://www.gentiger.com.tw)  
 Booth No.: J0410

### CNC 5-Axis Double Column Machining Center

Special for Difficult-to-Cut Materials processing, Titanium Alloy processing. Features:

- High-Rigidity structure design. Mechanical-type Simultaneous Two-Axis rotary spindle. Warm and gear transmission for B and C axes. With self-made heavy-

cutting two-stage gearbox design (Gear Ratio by 1:1.75 and 1:7). Maximum Torque: 1155 N-m.

- Unique patented design of the Z-axis spindle rail structure - vibration restrain in machining. It can largely reduce the vibration in machining hard-to-cut material, enhance the machining efficiency, reduce the surface roughness, and prolong the tool's life. (Model S5A-HH exclusive)
- Fully Splash Guarding design. Super large and wide working door design. Fashionable aesthetic and ergonomic safety design.
- Specific design of safety guardrail upon the cross column. Convenient for machine maintenance.
- Height-adjustable manipulation control box. Suitable for people of different height.

**SIGMA CNC Technology Machinery Co., Ltd.**

Tel: +886-4-2562-8000  
 Fax: +886-4-2562-1493  
 Email: [sigma.cnc@msa.hinet.net](mailto:sigma.cnc@msa.hinet.net)

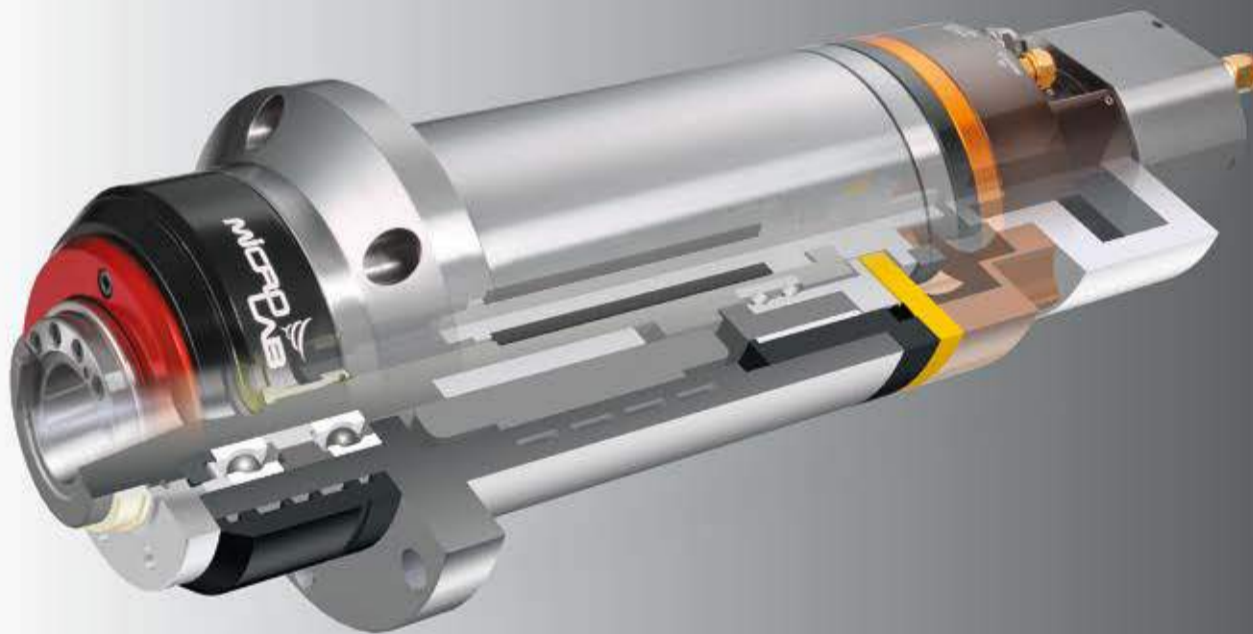

**Integration of High Performance Technology  
 Perfect Process Control to  
 Ensure Stable Quality**



**TIMTOS** March 4-9, 2019  
 TAIPEI NANGANG Exhibition Center, Hall 2  
 第 27 屆台北國際工具機展  
 The 27th Taipei Int'l Machine Tool Show  
**SITE: Q1212**

矩將科技有限公司|MicroLab Precision Technology Co.,Ltd|  
 Tel:+886-4-22392345 / Fax:+886-4-22392357 / E-mail:[microlab@twspindle.com](mailto:microlab@twspindle.com)  
 台中市40643北屯區松竹路一段530號  
<http://www.twspindle.com>

## Exhibit Highlights

### 2,500 Tons of Tandem Lines Customized for Automotive Manufacturing industry

Hydraulic system is easy to maintain and powered by the motor and pump set.



Moving bolsters with Q.D.S. system (quick die change system) to make the heavy die change easier and faster. Fast pressing speed is between 30 and 150 mm/s controlled by the accumulator and the approaching speed of 800 mm/s or faster and return of 600 mm/s or faster. With function of cushion system to knock out the parts. All speeds and strokes including the slide and cushion systems can be adjustable. The repetitive is within  $\pm 0.05$ mm. The DEES self-developed HD-FASTech technology completely solved deep-drawing's low efficiency, greatly improving production efficiency. The tandem line in photo is for working

24/7 and the customer which occupied more than 10% in market and in top 3 automotive manufacturing industries. DEES supplies the custom hydraulic presses with our in house design and manufacture which are strong and robust for long operations.

Ever since our establishment in 1976, basic philosophy of DEES Hydraulic is to provide customers the "complete engineering, manufacturing and solutions". Certified with ISO 9001 and CE, DEES offers safety and friendly interface of hydraulic presses in working environment of metal forming. The capacity of hydraulic press is from 10 to 6,000 tons, over 4,500 machines built to 80 countries in the world.

DEES supplies customers such as Bombardier, Boeing, Honda, Toyota, Audi, Volkswagen, Mercedes-Benz, Volvo, Boscho Group home appliances, Electrolux, GE home appliances, Haier, Foxconn, etc. DEES has supplied more than 4,500 customized hydraulic presses worldwide.

**DEES Hydraulic Industrial Co., Ltd.**

TEL: +886-2-2601-8661

FAX: +886-2-2601-8936

Email: sales@spc.com.tw

Website: www.deesgroup.com.tw

**Booth No.: TWTC Exhibition Hall 1/ D0401**

### SANJET: Tool Expert who Astound Customers

In TIMTOS 2019, SANJET brings its new CHAIN GRIPPER TYPE TOOL MAGAZINE WITH ARM which specially used in the five-axis CNC machine.

Integrated chain and gripper seat design improves assembly precision and efficiency massively. Continuous track designed chain structure provides smooth running and low backlash feature which performs precise positioning after long term usage.

SANJET original chain design combines gripper seat and magazine rail with rollers. Tool chain runs smoothly with roller rolling to reduce friction resistance. Motor drive force transmitted perfectly and saves the biggest cost.

Drifting transmission structure eliminates chain chord tolerance during chain running which ensure structure combines with chain stably. No need to adjust backlash.

Modular design, magazine preserved interface of expansion to increase tool loading capacity to 120 tools maximum.

Servo system provides program through I/O link feasible with any brand of controller and system which makes using "servo large loading capacity magazine" easy.

Founded in 2002, SANJET is committed to becoming a tool expert for all products. It focuses on producing high C/P value products. In 2016, SANJET built a new factory, thanks to the completion of the high -efficient production line, the capacity of SANJET increased by 50% at the second quarter of 2017. In 2019, it officially launched an automated production line to provide high-quality, high-stability products.

Sanjet insists on the developing strategy of build the "Owned brand", supplemented by the business model of "Customer-centered", to meet or even exceed customers' expectations through "Customization" will be Sanjet's goal with unremitting efforts in the future.

SANJET International Co., Ltd.

Tel : +886-4-2565 3819

Fax : +886-4-2565 0219

E-mail : sjatcms@sanjet.com.tw

Website : www.sanjet.com.tw

**Booth No.: TWTC Hall, G0518**



自1961年我們就在全球持續突破與創新，提供你全方位棒材加工

We deliver the innovation worldwide since 1961 in order to provide you the full range of bar-working



**Elite ZERO/112 / 220**

Ø 0.3 / Ø 0.8-12.7 / Ø 2-20  
1.8M/3.2M/3.7M



**Steady 326**

Ø 3-26  
3.2M



**Boss 542 / 551**

Ø 5-42 / Ø 5-51  
2.5M/3.2M/3.7M/4.4M



**Master Series**

Ø 8-80 / Ø 30-100  
2.1M/3.3M/3.8M/4.3M

中義科技機械(股)公司 GIULIANI IEMCA MACHINERY CO., LTD. Tel. 886-4-2406970

 **TIMTOS** Booth No. N0519  
Nangang Exhibition Hall 1  
We welcome your visit sincerely

# 70<sup>th</sup> ANNI WERSARY



**TIMTOS**  
27th Taipei Int'l Machine Tool Show

stand/

**10626**

**04 - 09, Mar. 2019**



“遠東機械集團—發得科技工業(股)”  
(Tel)+886 5 213 3166/(Fax)+886 5 220 5293  
62154嘉義縣民雄鄉福樂村中山路26號  
<http://www.FATEK.com.tw>



DEFINE FUTURE

品質成就信任，智能定義未來



製造智慧科技·彈指之間  
遠東E智慧服務系統

**FEMTEC** 遠東機械集團  
**GROUP**

## Go Taipei Things to Do in Taipei

### Visit Distinctive Neighborhoods

Each of Taipei's shopping areas has its own character. Visit Dadaocheng, Bangka, and Ximending, you can appreciate old buildings and traditional culture. The young generation has sown the seeds of creativity here and reinterpreted local culture, giving old blocks an irresistible charm. Taipei's East District is the place to search for fashionable stores, with Taipei 101 and the Xinyi shopping area serving as bustling fashion hubs. The lanes and alleys of Yongkang Street and Section 2 of Zhongshan North Road are characterized by distinctive culture. Search out some small stores with unique style and add more fun to your trip!



### Appreciate Arts and Culture

The world-famous National Palace Museum is a place where you can marvel at a staggering number of classic cultural relics of the Chinese imperial court dating back thousands of years; among its most popular exhibits are the Jadeite Cabbage and the Meat-shaped Stone. Taipei Fine Art Museum and Taipei Museum of Contemporary Art, Treasure Hill Artist Village and Spot Taipei, which specializes in showing art house movies, are the places to go to see the modern arts merged into daily life. The streets of the city have a distinct arts atmosphere as well; public art works can be seen all over and street artists can often be seen in the Xinyi shopping area and at Ximending, presenting stunning performances.



### See Cultural & Creative Attractions



In Taipei, quite a few old buildings have been given a new lease of life as cultural and creative design bases, to brilliant effect. Huashan 1914 Creative Park, once a distillery; Songshan Cultural and Creative Park, formerly a tobacco factory; The Red House, originally a market built a century ago; New ArtYard and ArtYard, housed in old buildings in Dadaocheng; and 44 South Village, retaining the appearance of an early military dependents' settlement, are all great places to find good designs and exhibitions amidst old-time charm.

### Enjoy a Hot-Spring Bath

One of the best things about Taipei is that you can hop on the MRT and arrive in Beitou, known for its steaming hot spring water and lush greenery, in less than an hour. Hot-spring bathing in the area dates back to the Japanese era, which is why Beitou Hot Spring Museum, Beitou Museum, and Plum Garden all are rich in Japanese charm. Taipei Public Library Beitou Branch's green building and the steam-veiled water at Thermal Valley are both unique sights. After a relaxing hot-spring bath, don't forget to check out Beitou Market and feel the old-time charm of its lanes and alleys!



### Worship at a Temple

Most of Taipei's early settlements developed around temples. Many of these are well over a century old, such as Bangka Longshan Temple, which is always busy; Taipei Xiahai City God Temple, where people pray for a happy family life; Dalongdong Baoan Temple, where worshippers pray for health; as well as Dadaocheng Cisheng Temple and Guandu Temple. These temples not only bear witness to the city's development, inside you will also find exquisite wood carvings, stone inscriptions, ceramic applique, calligraphy, and lifelike Buddha statues to admire.



### Drink Tea While Admiring the Scenery



Maokong, in the southeast corner of the city, offers rare scenes of tea plantations close to the city. The Wenshan Baozhong and Tieguanyin teas grown here are renowned. After walking past the tea fields on a hiking trail, stop off at a teahouse for a rest and enjoy drinking fine tea and eating tasty tea dishes. To get to Maokong take the Maokong Gondola and go on a ride which offers stunning views of green hills and tea plantations. Nangang Tea Processing Demonstration Center is another place to learn about tea culture. Offering fine teas from across Taiwan and various experiential activities, everyone is invited to drink tea and chat.

Text Source: Department of Information and Tourism, Taipei City Government

SOLPOWER

經典的工藝 · 精銳的演出

TIMTOS 2019  
Mar. 4-9  
27<sup>th</sup> Taipei Int'l Machine Tool Show  
南港二館一樓 P1028

# CHENG CHANG MACHINERY

HIGH PRECISION | LOW INERTIA | HIGH RESPONSIVITY

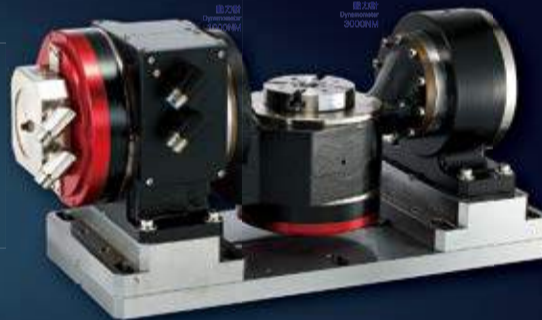

## 全系列伺服馬達

SOLPOWER SERVO MOTORS

### SVM系列 (IP54)感應伺服器馬達

Compact Asynchronous motors Quick positioning, High torque moment.

#### 產品特性

定位快速、精準、瞬間扭力大、低慣量設計、反應靈敏、高精度製程設計、符合您精密機械的需求。

#### 應用

工具機主軸、印刷機械、塑膠射出成形機、分條/複捲機械、包裝機械、紡織機械、一般產業機械。



### DD馬達 第四、五軸機構 · 內藏式主軸定轉子

Rotor&Stator(ER16,ER20,ISO250,BT30,BT40,P.C.B...等) / (100NT-M,200NT-M...等)

#### 產品特性

定轉子特性媲美進口產品，規格參數齊全，適合各廠牌驅動器、控制器、規格產品齊全，亦可訂製。

#### 應用

內藏式主軸、DD馬達。



### SVMA系列 (IP23)感應伺服器馬達

(IP23) Compact Asynchronous motors Quick positioning, High torque moment, Efficient cooling

#### 產品特性

定位快速、精準、瞬間扭力大、低慣量設計、反應靈敏、高效率冷卻設計、抗電波線圈、高精度製程設計、符合您精密機械的需求。

#### 應用

工具機主軸、印刷機械、塑膠射出成形機、壓鑄機、分條/複捲機械、包裝機械、紡織機械、沖床(延伸膜)、一般產業機械。

### LINEAR MOTOR 線性馬達

The ironcore design for the higher efficiency of linear motor, and the higher speed and positioning accuracy than ball screw.

#### 產品特性

有鐵心設計提高線性馬達效率。高效率的冷卻系統及較高的佔槽率大大提高線性馬達的功率體積比。

#### 應用

P,C,B鑽孔機、工具機、產業機械。



### SPMA系列 同步伺服器馬達

Compact Synchronous motors Good speed control & torque control.

#### 產品特性

高精度、低慣量設計、反應靈敏、速度控制、位置控制、轉矩控制、特性優越符合您精密機械的需求。

#### 應用

工具機主軸、印刷機械、塑膠射出成形機、分條/複捲機械、包裝機械、紡織機械、一般產業機械。



### DDM系列 直驅伺服器馬達

Suits injection molders, die-casting machines, machine tools, escalators, elevators, printers and industrial machines that require low speed, high-torque drive.

#### 產品特性

取代減速機構，節約設備成本，噪音低、效率高、低速高扭力，提高控制精度，提升產品品質。

#### 應用

注塑機攪拌、壓鑄機、工具機、電梯扶梯、印刷機械、一般產業機械、低速高扭力的應用。

晟昌機電股份有限公司 CHENG CHANG MACHINE ELECTRONIC CORP.

43641 台灣台中市清水區和陸路一段1005巷89號 | TEL : 886-4-26202888 | FAX : 886-4-26202777  
No.89, Ln. 1005, Sec. 1, Hemu Rd., Qingshui Dist., Taichung City 43641, Taiwan (R.O.C.)

廈門晟勝數控設備有限公司 XIAMEN CHENGSHENG NC EQUIPMENT CO., LTD.

廈門同安區金富路100號B棟3樓東側郵編361100 | TEL : 86-592-7191900 | FAX : 86-592-7191961  
No.100, B Building 3rd Floor East Side, Jin-Fu Road, Tong-An District, Xiamen City, 361100



Sol.power@solpower.com.tw  
Sol.power@msa.hinet.net



# 2019年台北國際工具機展

## 聚焦工業4.0、智慧製造、AI技術



中華民國對外貿易發展協會  
黃志芳董事長

**歡**迎各位嘉賓及國內外業者前來參與2019年台北國際工具機展(TIMTOS)!

首先感謝經濟部、台北市政府以及所有相關單位興建台北南港展覽館2館的努力與付出。今天南港2館的正式啟用是臺灣國家經濟與會展產業的重要盛事也是嶄新的里程碑，南港雙館—南港1館及南港2館將會是臺灣規模最大的國家級會展中心，也是國際會展產業在臺灣辦理MICE活動的最佳選擇。

第一個使用南港2館的大型國際展覽就是TIMTOS 2019，南港2館與南港1館、世貿1館及3館共同容納更多參展廠商，提供更臻完善的展覽條件。本屆TIMTOS展出規模達到7,000個攤位，再創該展與臺灣會展的歷史新高，成為全球第三大工具機展。

在現今數位化的時代裡，高科技對於公司業務、工廠生產與日常生活都有相當大的影響力。相當多臺灣企業已運用先進的ICT技術來提升生產力，進而促進產業數位化發展，臺灣機械廠也不例外。臺灣機械產業實力雄厚，擁有全方位整合的產業供應鏈以及堅強的研發能力，機械廠也正運用創新科技研發智慧機械與完整解決方案，以協助製造業者打造智慧工廠，提升生產效率。

TIMTOS也隨著全球工業革命發展，從大量生產的時代到現今工業4.0的時代。本屆TIMTOS以「工業4.0、智慧機械」為主題，搭配AI技術，整合各項系統，展出一系列結合工具機、工業機器人、感測器、IoT、大數據分析、機器學習與AI技術的智慧化及數位化解決方案，使自動化生產線更有效率、有彈性。

此外，為協助業者掌握國際製造業發展趨勢，今年辦理的第二屆TIMTOS高峰論壇，邀請到全球知名企業的高階主管及產業專家，針對「智慧聯網」、「積層製造」、「航太智慧製造」及「汽車製造業變革」等主題，分享最新產業趨勢與市場脈動，絕對是精彩可期。

面對經貿多變的情勢與數位化的浪潮，外貿協會將持續為臺灣業者打造一個展示創新科技和智慧化技術以及拓展海外商機的平台，加速推動臺灣成為智慧製造王國。

再次感謝各位嘉賓與業者的支持和熱情參與，祝福今年來觀展的買主與參展廠商都能豐收滿載而歸、生意興隆! ■

中華民國對外貿易發展協會  
黃志芳董事長



臺灣機械工業同業公會  
柯拔希理事長

造專家擔任評審委員，分類分項進行評審，競爭激烈，得獎名單將於明晚的酒會揭曉。

### 技職與高教的教育務實化， 產學研合作更升級

台北國際工具機展不僅是全球參展廠商展現實力的舞台，也是延攬產業優秀人才踏入機械業的最佳平台。掌握人才，撼動未來。今年報名參觀本展的學生團體非常踴躍，共計有53所學校、141個班級團體、超過7,200人次組團前來觀摩學習，總人數較上屆倍數成長。非常感謝教育部和相關單位積極協助推廣，促成上述活動順利進行，落實技職與高教的教育務實化。

展覽會場上，除了(以往)工研院及精密機械研究發展中心，還多了許多新面孔，包括中正大學、虎尾科技大學、以及科技部工程司的國際產學聯盟等單位，前來共襄盛舉，希望未來有更多學研單位，一同參與這場工具機盛宴。

### 深耕智慧機械與智慧製造， 邁向2兆產值目標

臺灣機械產業持續成長，前年(2017)臺灣機械業產值突破新台幣兆元目標，達到1.1兆元，去年(2018)機械業出口值274億美元，成長7.2%，而生產值再增加約800億元、達到1.18兆元，成長約7.3%，續創歷史新高，而工具機產業出口值36.6億美元，較去年成長9.5%。

去年8月，機械公會發表智慧機械產業白皮書，規劃未來持續朝向智慧機

械與智慧製造的方向邁進，期許臺灣成為全球的「智慧機械製造王國」。智慧機械是智慧製造的基礎，沒有智慧機械，就沒有智慧製造。

今年，機械公會將扮演催生和推動的角色，力推智慧機械上雲端，用共享經濟的概念發展公版機械雲，建立機械雲端服務平台的軟硬體系統與示範運行服務團隊，推動並協助設備業者導入機械雲服務。發展智慧機械與智慧製造所創造的高附加價值，將可實現在2025年機械業產值達到2兆台幣的願景。

### 今年景氣先蹲後跳，觀察美 中貿易戰、布局新南向

臺灣工具機產業因出口占七成以上，未來發展還是要觀察今年全球景氣的變化。去年第4季開始投資縮手，市場觀望氣氛濃厚，部分機械業的廠商接單出現反轉。預估今年上半年，因美中貿易戰與英國脫歐仍有變數，我們先保守看待，但今年下半年表現有機會優於上半年，今年景氣可維持先蹲後跳的格局。

因應美中貿易戰變數，海外設立第二生產基地的需求逐漸發酵。特別是越南和印度市場，未來商機可期。本次展會預計潛在訂單可達16億美元，全年產業成長幅度大約在5~10%區間，如下半年表現不錯，全年產業有機會成長10%。

### 盼政府作機械業強力後盾， 提升競爭價值

面對詭譎多變的經濟大環境，我們

期盼政府保護臺灣機械業的出口設備產品，希望中央銀行能啟動防禦性貶值，避免機械出口設備受到新台幣匯率波動影響。

期盼政府增列機械類股，協助機械業上市櫃，加速機械業在金融市場募資，以期3年內達到50家以上規模。

我們也希望立法院能盡速通過產業創新條例修正草案，讓智慧機械列入投資抵減項目，讓臺灣機械產業適用優惠政策，以協助產業提升競爭力。

本屆展會在各方努力之下，台北國際工具機展創下許多新的紀錄，包括躍升為全臺規模最大的國際展會。未來，我們會以謙虛謹慎的態度、更穩健踏實的脚步，努力為機械業也為臺灣的經濟，成就更多榮耀。

再次感謝各位長官、嘉賓、媒體前來參與此次盛會，各位的熱情參與，就是對機械產業界最大的支持與鼓勵。在此祝福各位貴賓身體健康，萬事如意，事業興隆，謝謝。 ■

臺灣機械工業同業公會  
柯拔希理事長

**感**謝來自產官學研各界的貴賓、國內外買主，以及媒體朋友們，撥空蒞臨TIMTOS，給予本展支持與指教。僅代表機械公會與所有參展廠商，向各位致謝。

### 展會規模創新高，研究發展 創新競賽將揭曉

今年台北國際工具機展，因為南港展覽館2館正式啟用，由全球第五大躍升為全球第三大工具機展，僅次於德國EMO和美國IMTS展，總展出1,230家廠商，使用7,000個攤位，創歷史新高。

呼應本屆展會主軸「工業4.0與智慧機械」，同期辦理的工具機研究發展創新產品競賽，今年特別增列智慧機械獎項，以厚植產業實力，持續鼓勵廠商研發創新。本屆共計受理43件參賽作品，聘請國內(外)知名工具機設計與製

Scan QR-Code and View  
more on APP and Wechat



TIMTOS APP



Wechat

展覽新聞

# 瑞士國家館於2019年台北國際工具機展盛大展出

由瑞士商務辦事處、瑞士機械、電子及金屬產業公會(Swissmem)及十六家瑞士在台分公司與代理商籌組之瑞士館，於2019年台北國際工具機展，盛大展出瑞士原廠品牌之工具機及工具最先進的技術。本屆瑞士館位於南港展覽館四樓展場，涵蓋一百零五個攤位，九百四十五平方米，是展場中最大的國家館。館中展出包括磨床、銑床、刨床、車床、搪床、放電加工機、齒輪加工機、成型機等瑞士工具機產業最先進之機械與設備，提供符合各種不同產業需求之買家。瑞士館的組成及展出，凸顯了瑞士廠商對台灣工具機產業的重視，暨對本地客戶需求的專注。

## 瑞士館展出重點

瑞士館主辦單位瑞士商務辦事處傅瑞處長指出，“本屆瑞士館展出重點在於瑞士公司所提供之生產流程創新及彈性的解決方案。在不斷競爭及產業升級的環境下，更精密、更快速、更具生產力，並提供使用者友善的使用介面是



最重要的幾項元素；瑞士工具機產業涵蓋中高階切削機、成型機和各種特殊用途機具，瑞士工具機廠商專精於解決各種困難複雜的問題，提供客戶量身定做與最新的技術方案。瑞士工具機主要客戶包括機械產業、自動化產業、航太工業、光學醫療儀器、微型機械產業、手錶及國防工業等。使用高效率、針對特定範疇的機器，比使用低價格、用於一般製造的機器，實為更好的選擇，因為一件成品的最終成本才是最重要的考量因素，成本的計算方式並不僅僅包括購買製造機器或設備的費用，同時也必須包含整個生產過程中的花費，如電力的消耗、生產所需時間、成品和良率。瑞士工具機是生產者最佳的夥伴。”■  
本屆瑞士館位於南港展覽館1館4樓展場

# 美國國家館於2019年台北國際工具機展盛大展出

由美國在台協會商務組及7家美國在台分公司與代理商籌組之美國館，於2019年台北國際工具機展，盛大展出美國廠品牌之工具機及工具零組



件、量測設備、CAD/CAM軟體等等最先進製造的技術。本屆美國館位於南港展覽館1館4樓展場，展出廠商有哈斯、海克斯康、舜格、達康科技、鉅偉、捷鉞及喜瑞仙。美國機械製造業在先進製造夥伴計劃 (AMP) 的幫助下，創造出高水準，具全球競爭力的產品。

本屆美國館位於南港展覽館四樓展場，涵蓋28個攤位。館中展出包括：  
HAAS哈斯：綜合加工機&車床  
OMAX舜格：水刀  
HEXAGON海克斯康：量測設備  
Delcam達康科技：CAD/CAM軟體  
Martin捷鉞：傳動零件  
ESPRIT鉅偉：CAD/CAM軟體  
SUNNEN喜瑞仙：精密搪床  
此次美國品牌廠商尚有10餘家廠商分散各展場中：HARDINGE 哈廷、HURCO赫可、SETCO日紳、GLEASON

隆答、Solid Wizard實威、Controltek 康德克、SAGINAW 薩吉諾機械、GARDNER BUSINESS MEDIA。

## 美國館展出重點

本屆美國館展出重點在於美國公司所提供之生產流程創新及彈性的解決方案。在不斷競爭及產業升級的環境下，更精密、更快速、更具生產力，並提供使用者友善的使用介面是最重要的幾項元素；美國工具機產業結合傳統工藝及最新IT科技，美國工具機廠商專精於解決各種困難複雜的問題，提供客戶量身定做與最新的技術方案。美國工具機主要客戶包括機械產業、自動化產業、航太工業、汽車產業、國防工業等，光學醫療儀器、能源科技。■  
本屆美國館位於南港展覽館1館4樓展場

**HEIDENHAIN**  
海德漢股份有限公司  
<http://www.heidenhain.tw>

**TIMTOS**  
攤位號碼：南港二館 Q0124  
2019年3月4~9日

更多TNC訊息  
請參考海德漢  
控制器系列新聞

# 德國市場領導者的世界級智慧 產業解決方案

**智**能工業的概念目前對工業技術和生產系統產生了深遠的影響。智能工業及其智能製造系統依賴於機械工程，這是德國的核心產業之一。2016年，機械工程行業是德國第二大工業部門，擁有超過100萬名員工，收入超過2700億歐元。精確、高質量和高效率是全球成功的基礎，也是德國機械工程公司的國際聲譽。

德國為台灣在工具機方面最重要的前四大貿易夥伴之一，許多德國公司一直為台灣市場提供必要的工具機例如藉由分散式的生產方式及有效率的客製化生產以及機動性的公司以應對當前智能製造的挑戰。憑藉多年來積累的專業知識以及作為機械行業創新生產技術和製造研發領域的全球領導者，德國公司滿足了作為智能行業先鋒所需的所有先決條件。

繼2017年TIMTOS德國館成功地展出後，今年德國經濟辦事處及其服務執行單位-博智顧問公司再度攜手舉辦2019年TIMTOS德國館，並匯聚以下25家的德國頂尖工具機械公司一同在德國館大放異彩：

台灣巴魯夫有限公司、德商波龍科技有限公司台灣分公司、帥風貿易有限公司、德商吉伯特科技軸承有限公司、新加坡商哈威有限公司、錫睿有限公司、台灣開天傳動科技有限公司、盟達實業股份有限公司、奈米趨勢科技、台灣奧奔麥科技股份有限公司、菲尼克斯有限公司、景盛企業有限公司、台灣雄克股份有限公司、歐通克股份有限公司、德商斯德博動技術有限合夥台灣分支機構、WTO、雍青企業股份有限公司(以上17家展商均位於南港展覽館1館4樓)以及CyTec Zylindertechnik GmbH, DWT GmbH, EUCHNER GmbH + Co. KG, Honsberg Metalsagen GmbH、相成有限公司、Precitec Asia Ltd、ZF Friedrichshafen AG、名人精密機械有限公司(以上8家展商均位於台北世貿展覽館1館)，將展示德國首屈一指的工具機械相關產品及技術和智能製造之解決方案。

TIMTOS歡迎德國館在南港展覽館1館4樓以及台北世貿中心展覽館大樓1館盛大的展出

德國經濟辦事處誠邀您一同參與以下德國館之活動：啤酒暢飲活動  
3月7日(四)15:00-17:00 於南港展覽館1館4樓N區德國館台灣雄克攤位(N0512)；  
3月8日(五)15:00-17:00於台北世貿中心展覽館一館1樓A區的德國館(於A1222 及A1212間的走道)  
歡迎至德國館免費參加德國館的傳統活動，並暢飲由瑞新國際興業有限公司贊助的HB慕尼黑皇家啤酒！有獎徵答活動將在此活動同時舉行！



## 超強動力 來自完美結構

GT新虎將 專業三軸·五軸高速機



**GT-1612V**  
門型高速加工中心機  
High Speed Double Column Machining Center



**GT-SP45 Linear**  
門型超精密線馬型加工中心機  
Ultra High Precision Double Column Machining Center with Linear Motor Drive



**GT-ML800**  
五軸銑車複合機  
5 axis Mill-Turn Machining Center



**GT-H2517F**  
天車式五軸高速加工中心機  
Gantry type 5 axis High Speed Machining Center

**新虎將機械工業股份有限公司**  
GENTIGER MACHINERY INDUSTRIAL CO., LTD.  
www.gentiger.com.tw E-mail: GT@gentiger.com.tw  
Tel: +886-4-2683 6919 Fax: +886-4-2683 9900

**精密銑床、CNC 高速機領導品牌**

**「2019台北國際工具機展」接駁車資訊**  
本展覽地點為南港展覽館1館、2館及世貿1、3館，主辦單位提供之免費接駁車資訊如下：

路線	行駛時間/上車地點/車輛數
世貿一館 ↔ 南港展覽館 (對開)	3/4-8 : 10:00-18:00 3/9 : 10:00-15:30 一館：市府路 南港：1館正門 (平均10分鐘一班)

## 「2019年台北國際工具機展」研討會/活動日程表

日期	時間	活動內容 / 講題	主 / 協辦單位	地點	備註	
3月4日 (星期一)	10:30	開幕典禮	外貿協會·機械公會	南港展覽館 2 館 4 樓門廳	憑邀請函入場 簡韻茗小姐 +886-2-27255200#2867	
	8:00-17:00	Bfuture 全球新品發布會	慶鴻機電工業股份有限公司	南港展覽館 1 館 402c 會議室	林盈函小姐 +886-4-23509188#527	
	8:00-17:00	發格控制器及光學尺產品介紹	發格自動化股份有限公司	南港展覽館 2 館 602 會議室	溫恕民先生 +886-4-23851558	
	13:30-16:30	2019 台北國際工具機展採購洽談會	外貿協會	南港展覽館 1 館 504 會議室	柯采慧小姐 +886-2-27255200#1573	
	14:00-15:00	2019 台北國際工具機展記者會	外貿協會·機械公會	南港展覽館 1 館 403 會議室	侯馨青小姐 +886-2-23494677	
	16:00-17:30	馬來西亞機械市場說明會暨 TAITRA 及 PENFEIA 合作備忘錄簽約典禮	外貿協會	南港展覽館 1 館 404 會議室	陳冠儒小姐 +886-2-27255200#2693	
3月5日 (星期二)	8:00-17:00	Bfuture 全球新品發布會	慶鴻機電工業股份有限公司	南港展覽館 1 館 402c 會議室	林盈函小姐 +886-4-23509188#527	
	8:00-17:00	發格控制器及光學尺產品介紹	發格自動化股份有限公司	南港展覽館 2 館 602 會議室	溫恕民先生 +886-4-23851558	
	8:30-12:00	工具機關鍵模組暨智慧製造應用技術發表	工研院智慧機械科技中心	南港展覽館 1 館 505a 會議室	張惠怡小姐 +886-49-2345309	
	9:00-12:00	台日機械企業經貿交流會	機械公會	南港展覽館 1 館 504bc 會議室	王篠傑先生 +886-2-23494668	
	9:00-16:00	TIMTOS 2019 高峰論壇	經濟部國際貿易局	台北國際會議中心 101 會議室	高麗茹小姐 +886-2-27255200#2679	
	16:00-17:00	德國工藝 享譽國際 - 德國工具機產業發展新趨勢	外貿協會德經處	台北國際會議中心 101 會議室	鄭芳姿小姐 +886-2-7735-7524	
	10:00-12:00	《工具機組裝新利器 -Renishaw 全新 XK10 校準雷射系統》新品發表會	雷尼紹股份有限公司	南港展覽館 1 館 402a 會議室	莊詠偉先生 +886-4-24603799	
	10:30-12:00	TNC 640 高效率五軸輪廓控制器 - 高可靠度創新加工技術的優勢	海德漢股份有限公司	南港展覽館 1 館 403 會議室	蔡語耕小姐 +886-4-2358-8977 #1035	
	13:00-15:00	NIDEC-Commander C 產品發表會	睿欣實業股份有限公司	世貿一館 第 4 會議室	陳曦小姐 +886-4-22606502	
	13:00-15:00	工業 4.0 智慧製造研討會 / 模具智能化生產單元	徠通科技股份有限公司	南港展覽館 1 館 402ab 會議室	張詠晴小姐 +886-4-23599688#226	
	15:30-18:00	徠通科技全球代理商會議	徠通科技股份有限公司	南港展覽館 1 館 402ab 會議室	張詠晴小姐 +886-4-23599688#226	
	14:00-15:00	2020 年日本國際工具機展覽會 JIMTOF 記者會	日本工作機械工業會	南港展覽館 1 館 404 會議室	+81-3-34343961	
	14:30-16:30	智慧製造聯網數據加值產業聯盟會員大會	財團法人工業技術研究院 ITRI	南港展覽館 1 館 504a 會議室	陳玉雲小姐 +886-3-5916720	
	15:00-16:00	臺灣機械工業同業公會與馬來西亞檳城機器廠商會簽訂合作協議	機械公會	南港展覽館 1 館 4 樓貴賓簡報室	林子鈞先生 +886-2-23494694	
	15:00-17:30	台灣麗馳全球代理商大會暨新產品發表會	台灣麗馳科技股份有限公司	南港展覽館 1 館 401 會議室	莫金燕小姐 +886-4-26815711#246	
	18:30	2019 年台北國際工具機展歡迎酒會暨工具機研究發展創新產品競賽頒獎典禮	工具機發展基金會·外貿協會·機械公會	南港展覽館 1 館 3 樓燴館宴會廳	蔡宜真小姐 +886-2-23110358	
	3月6日 (星期三)	8:00-17:00	Bfuture 全球新品發布會	慶鴻機電工業股份有限公司	南港展覽館 1 館 402c 會議室	林盈函小姐 +886-4-23509188#527
		8:00-17:00	「2019 年台北國際工具機展」高中職、大專、大學、研究所導覽活動	機械公會	南港展覽館 1 館 500 會議室	黃雅華小姐 +886-2-23494672
8:00-17:00		發格控制器及光學尺產品介紹	發格自動化股份有限公司	南港展覽館 2 館 602 會議室	溫恕民先生 +886-4-23851558	
9:00-16:00		TIMTOS 2019 高峰論壇	經濟部國際貿易局	台北國際會議中心 101 會議室	高麗茹小姐 +886-2-27255200#2679	
16:00-17:00		德國工藝 享譽國際 - 德國工具機產業發展新趨勢	外貿協會德經處	台北國際會議中心 101 會議室	鄭芳姿小姐 +886-2-7735-7524	
8:00-17:00		工業 4.0 與智慧機械技術應用趨勢研討會	台灣易格斯有限公司 遠播資訊股份有限公司	南港展覽館 1 館 505 會議室	孫桂芬小姐 +886-2-25855526#225	
9:00-11:00		永進機械代理商會議	永進機械工業股份有限公司	南港展覽館 1 館 401 會議室	陳家欣小姐 +886-4-25623211#1812	
10:30-12:00		選擇美國投資研討會 - 錢進美國教戰守則	美國在台協會商務組 臺灣機械工業同業公會	南港展覽館 1 館 501 會議室	+886-2-27201550#334	
13:00-17:00		新產品說明會	喬崑進科技股份有限公司	南港展覽館 1 館 502 會議室	黃悖密小姐 +886-4-22712000#231	
13:00-17:00		程泰集團年度產品發表會	程泰集團	南港展覽館 1 館 504a 會議室	江苡璉小姐 +886-4-24629698#62107	
13:30-16:30		礦物複合材料 (人造花崗石) 在機械領域的應用	山東納諾新材料科技有限公司	南港展覽館 1 館 404 會議室	崔美麗小姐 +86-531-88917773	
13:30-17:00		中國砂輪新產品發表會	中國砂輪企業股份有限公司	世貿一館 第 2 會議室	王文仁先生 +886-2-26791931#3309	
8:00-17:00		直得科技新品說明會	直得科技股份有限公司	南港展覽館 1 館 3 樓福軒	李家慶先生 +886-6-5055858#162	
8:00-17:00		Bfuture 全球新品發布會	慶鴻機電工業股份有限公司	南港展覽館 1 館 402c 會議室	林盈函小姐 +886-4-23509188#527	
8:00-17:00		「2019 年台北國際工具機展」高中職、大專、大學、研究所導覽活動	機械公會	南港展覽館 1 館 500 會議室	黃雅華小姐 +886-2-23494672	
8:00-17:00		發格控制器及光學尺產品介紹	發格自動化股份有限公司	南港展覽館 2 館 602 會議室	溫恕民先生 +886-4-23851558	
13:30-17:00		2019 台北國際工具機展 GLORIA 智慧製造創新應用論壇	科技部·外貿協會·機械公會	南港展覽館 1 館 402ab 會議室	郭瑀璇小姐 886-2-25774249#827	
14:00-16:00		液壓系統節能技術與切削冷卻液之過濾處理	台灣賀德克技術有限公司 得霖企業有限公司	南港展覽館 1 館 502 會議室	楊雅淑小姐 +886-4-22602278	
14:00-16:00	研磨加工品質、效率的確保與提升	忠達貿易有限公司	南港展覽館 1 館 505b 會議室	張怡婷小姐 +886-2-29115226#607		
3月7日 (星期四)	8:00-17:00	直得科技新品說明會	直得科技股份有限公司	南港展覽館 1 館 3 樓福軒	李家慶先生 +886-6-5055858#162	
	8:00-17:00	Bfuture 全球新品發布會	慶鴻機電工業股份有限公司	南港展覽館 1 館 402c 會議室	林盈函小姐 +886-4-23509188#527	
	8:00-17:00	「2019 年台北國際工具機展」高中職、大專、大學、研究所導覽活動	機械公會	南港展覽館 1 館 500 會議室	黃雅華小姐 +886-2-23494672	
	8:00-17:00	發格控制器及光學尺產品介紹	發格自動化股份有限公司	南港展覽館 2 館 602 會議室	溫恕民先生 +886-4-23851558	
	13:30-17:00	2019 台北國際工具機展 GLORIA 智慧製造創新應用論壇	科技部·外貿協會·機械公會	南港展覽館 1 館 402ab 會議室	郭瑀璇小姐 +886-2-25774249#827	
	14:00-16:00	液壓系統節能技術與切削冷卻液之過濾處理	台灣賀德克技術有限公司 得霖企業有限公司	南港展覽館 1 館 502 會議室	楊雅淑小姐 886-4-22602278	
	14:00-16:00	研磨加工品質、效率的確保與提升	忠達貿易有限公司	南港展覽館 1 館 505b 會議室	張怡婷小姐 +886-2-29115226#607	
3月8日 (星期五)	8:00-17:00	直得科技新品說明會	直得科技股份有限公司	南港展覽館 1 館 3 樓福軒	李家慶先生 +886-6-5055858#162	
	8:00-17:00	Bfuture 全球新品發布會	慶鴻機電工業股份有限公司	南港展覽館 1 館 402c 會議室	林盈函小姐 +886-4-23509188#527	
	8:00-17:00	「2019 年台北國際工具機展」高中職、大專、大學、研究所導覽活動	機械公會	南港展覽館 1 館 500 會議室	黃雅華小姐 +886-2-23494672	
	8:00-17:00	發格控制器及光學尺產品介紹	發格自動化股份有限公司	南港展覽館 2 館 602 會議室	溫恕民先生 +886-4-23851558	
	9:30-18:00	智慧製造論壇	流線傳媒股份有限公司 外貿協會	世貿一館 第 4、5 會議室	林淑靜小姐 +886-2-87715865#180	
	9:30-14:00	迪普馬移動解決方案產品培訓研討會	迪普馬移動解決方案集團公司 羅昇企業股份有限公司	南港展覽館 1 館 502 會議室	吳容睿小姐 +886-2-29958400#1232	
	10:00-17:00	中興大學與精密機械研究發展中心 智慧機械產學論壇技術成果發表會	國立中興大學 & 財團法人精密機械研究發展中心	南港展覽館 1 館 403 會議室	葉湘琳小姐 +886-4-22858139	
	13:00-16:00	活用 3D 列印與 3D 量測科技，邁入 3D 智能檢測時代	馬路科技顧問股份有限公司	南港展覽館 1 館 404 會議室	林雨潔小姐 +886-2-2999-6788#284	
3月9日 (星期五)	8:00-17:00	「2019 年台北國際工具機展」高中職、大專、大學、研究所導覽活動	機械公會	南港展覽館 1 館 500 會議室	黃雅華小姐 +886-2-23494672	
	8:00-17:00	發格控制器及光學尺產品介紹	發格自動化股份有限公司	南港展覽館 2 館 602 會議室	溫恕民先生 +886-4-23851558	

如有修正，以現場實際狀況為準，不另通知。

## 台北南港展覽館2館TaiNEX 2 首次與您相遇

**台**北南港展覽館2館 (Taipei Nangang Exhibition Center, Hall 2, 以下簡稱TaiNEX 2) 為南港會展中心擴建計畫標的，委由經濟部投資興建，委由貿協營運管理，於今日(2019年3月4日)正式啟用，開幕首展就是重量級國際展覽—全球第3大及亞洲第2大的台北國際工具機展TIMTOS 2019!

TaiNEX 2為全臺首座榮獲「黃金級綠建築標章」的專業展覽場館，樓地板面積達156,700平方公尺，容留人數達

32,000人；連結雙捷運並設有1,296個充足停車位，一樓展場及四樓展場分別挑高12米及9米，展現宏偉大器氣勢。

於今年11月即將啟用的7樓多功能會議中心，為全臺最大無柱可容納3,600人會議空間，搭配室內星空長廊與戶外6,100平方公尺的空中花園連結，可遠眺台北101美景，目前已有多个國際年會主辦單位前往場勘洽詢檔期，將成為會展業界辦理MICE活動的極佳選擇，例如2021年的國際扶輪社

世界年會將選用南港1館(TaiNEX 1)及南港2館(TaiNEX 2)。

未來南港雙館TaiNEX 1及TaiNEX 2合計可提供5,000個攤位與38間分組會議室，將成為臺灣最大的國家級會展中心；TIMTOS 2019受惠於TaiNEX 2的啟用，展出規模擴增至7,000個攤位，今年台北國際自行車展、台北國際電腦展等多項國際級大型展覽，亦得以擴大展出面積，將共同創下臺灣會展業界新里程碑。

TaiNEX 水波起伏的屋頂意象，呼應TaiNEX 1船桅建築，象徵南港雙館這個國家級會展中心，未來將搭載臺灣會展產業揚帆航向國際，一同開創我國會展產業在亞洲及全球的新局面，讓臺灣會展產業在亞太地區排名向上躍升。■

**TaiNEX 2新聞資料聯絡：**  
南港國際展覽中心2館 陳瑾緻高專  
02-2725-5200 #6616  
macy@taitra.org.tw



## BLÚ R-進化，工具機上的尖端解決方案 ——單纜線控制網絡，機台內部網絡的革命性新概念



BLÚ: 工具機上的尖端解決方案

**今**年TIMTOS，作為生產現場幾何測量與控制的領導者，Marposs將提出工具機上的尖端解決方案。

現今工具機世界，越來越彈性的機台是其特色，能讓加工過程持續受到

控制，並以智慧且有效的方式分享訊息。對此進化，來自Marposs的回應就是BLÚ。BLÚ展現了工具機內部網絡的革命性概念。

BLÚ - 單纜線控制網絡 - 是一個創

新的系統，能夠即時連結機台內所有監控感應器。系統包括主單元，即主節點，安裝在機台電氣箱內部（乾區Dry Area）。由此以一條MMSB纜線（MMSB - 馬波斯量測感應器匯流排 Marposs Measure Sensor Bus）進入機台內加工區域（溼區Wet），並與直接連接各式感應器的功能節點連結。

新的鏈狀構造比起之前星狀結構（所有加工區域內的感應器，均需將各自訊號線連結到主機），來得更具彈性，也更易客製化。

與機台間介面由主節點進行，可以是現場匯流排（Fieldbus），或並列埠I/O（parallel I/O）。功能節點彼此可以直接連結，或透過MMSB纜線相接，端依機台布局而定。

技術上的好處是，能夠客製化系統配置，並依機台布局而訂做。更進一步，當系統配置已確定後，未來只需增加功能節點到鏈狀結構內，即可擴充系統功能。

另一項創新是採用了7寸電容式觸控顯示幕 - 自從前只能屈就於小顯示幕，並得以實體按鍵操作，向前邁進了一大步。

BLÚ打開了今日定義的「智慧工廠」的大門 - 它的目標，就是透過監控系統所取得的關件資料與參數，以提供越來越優化，及整合的製程。

它能夠自機台內部各式感應器，獲得龐大資料總量。不同資料可用於各層級應用。小從機台操作者監看所有加工參數，以確保製程在掌控中，以至機台維護時機判斷，甚至是ERP。

來自感應器或監視點的這些資料，可提供「即時參數」，或進行處理及儲存，以用於各式分析。■

**要知道更多內容，**  
請參觀TIMTOS，我們在南港二館一樓  
P0320展位，  
或是我們官網：  
網址：[www.blu.marposs.com](http://www.blu.marposs.com)  
[www.marposs.com](http://www.marposs.com)

# 2019 年台北國際工具機展 高峰論壇

時間：2019年3月5日(二) 09:00-17:00  
地點：臺北國際會議中心101會議室 (臺北市信義區信義路五段1號)

時間：2019年3月6日(三) 09:00-17:00  
地點：臺北國際會議中心101會議室(臺北市信義區信義路五段1號)

主題一：智慧聯網	
時間	議程/講師
09:00-09:20	來賓報到
09:20-09:30	開場致詞 林芳苗 / 中華民國對外貿易發展協會副秘書長 柯拔希 / 臺灣機械工業同業公會理事長
09:30-10:10	【主題演講】How SAP helps Customers to Create Value with Industry 4.0 and Internet of Things in Discrete Industries Bernhard Meyer / SAP Global Solution Manager, Industry Business Unit, Industrial Machinery & Components (IM&C)
10:10-10:50	【主題演講】智能IoT智能機器管理平台 劉新正 / ITTS東捷資訊服務副總經理
10:50-11:30	【主題演講】從產學實踐台灣工業物聯網應用 覺文郁 / 虎尾科技大學校長
11:30-12:10	【主題演講】工業AI和工業互聯網未來趨勢分析 李傑 / 美國辛辛那提大學教授
12:10-12:30	【主題對談】未來製造工作型態 主持人：莊國欽 / 台灣區機械工業同業公會榮譽理事長 對談貴賓：所有主講人
主題二：積層製造	
時間	議程/講師
13:00-13:30	來賓報到
13:30-14:10	【主題演講】未來製造業的高端加工技術解決方案 Neun Harald / DMG MORI 營運長
14:10-14:50	【主題演講】The Evolution of Metal Additive Manufacturing: Leveraging the Machine Tool Infrastructure Pascal Pierra / Optomec 亞太區總監
14:50-15:20	【主題演講】增材智造實現快速生產 楊奇杰 / 馬路科技大中華區銷售經理
15:20-16:00	【主題對談】洞悉金屬3D列印未來發展 主持人：黃亮暉 / 數位時代創新長
16:00-17:00	德國工藝享譽國際—德國工具機產業發展新趨勢

主題三：汽車製造業變革	
時間	議程/講師
09:00-9:20	來賓報到
09:20-10:00	【主題演講】駕馭高動態加工技術的開創性解決方案 Peter Topol / 海德漢資深產品經理
10:00-10:40	【主題演講】實現工業4.0—與西門子共創數位未來 Tino Hildebrand / 臺灣西門子副總經理
10:40-11:20	【主題演講】數位化協作與創新—啟動航太製造的工業復興! Rémi GERMAIN / 達梭系統全球策略聯盟副總裁
11:20-12:00	【主題演講】Advanced manufacturing technologies Cyrille SCHWOB / 空中巴士公司亞太區總監
12:00-12:30	【主題對談】變革中的製造業—預見未來五年 主持人：胡竹生 / 工研院機械與系統研究所所長 對談貴賓：所有主講人
主題四：汽車製造業變革	
時間	議程/講師
13:00-13:30	來賓報到
13:30-14:10	【主題演講】智慧製造全新局面來臨·工業機器人的創新技術及應用 鍾鴻鈞 / ABB區域經理-服務銷售(東南亞及台灣)
14:10-14:50	【主題演講】CNC Systems for Factory of the Future 陳俊隆 / 博士力士樂股份有限公司工廠自動化協理
14:50-15:20	【主題演講】實現工業4.1的智慧工廠自動化 鄭芳田 / 成功大學智慧製造研究中心講座教授兼主任
15:20-16:00	【主題對談】改革正在加速·我們準備好了嗎? 主持人：胡竹生 / 工研院機械與系統研究所所長 對談貴賓：所有主講人
16:00-17:00	德國工藝享譽國際—德國工具機產業發展新趨勢

\*主辦單位保留議程變更及參加資格審核之權利  
\*現場提供中英文口譯

## 活動嘉賓

**Bernhard Meyer**  
SAP Global Solution Manager, Industry Business Unit, Industrial Machinery & Components (IM&C)



**Neun Harald**  
DMG MORI 營運長



**Peter Topol**  
海德漢資深產品經理



**胡竹生**  
工研院機械與系統研究所所長



**劉新正**  
ITTS東捷資訊服務副總經理



**Pascal Pierra**  
Optomec 亞太區總監



**Tino Hildebrand**  
臺灣西門子副總經理



**鍾鴻鈞**  
ABB區域經理-服務銷售(東南亞及台灣)



**覺文郁**  
虎尾科技大學校長



**楊奇杰**  
馬路科技大中華區銷售經理



**Rémi GERMAIN**  
達梭系統全球策略聯盟副總裁



**陳俊隆**  
博士力士樂股份有限公司工廠自動化協理



**李傑**  
美國辛辛那提大學教授



**黃亮暉**  
數位時代創新長



**Cyrille SCHWOB**  
空中巴士公司亞太區總監



**鄭芳田**  
成功大學智慧製造研究中心主任



# 中國大陸數控工具機市場潛力巨大

**據** 中國前瞻產業研究院發佈的《2018-2023年中國數控機床行業市場需求預測與投資戰略規劃分析報告》顯示，2018-2023年，中國大陸數控工具機由於技術發展以及下游市場逐漸復甦等原因，仍會保持10%-12%的增長速度。到2023年，中國大陸數控工具機行業的市場規模將突破5,000億元。

## 下游應用仍以汽車產業為主，消費電子將成未來應用主流市場

從數控工具機行業下游消費需求比重來看，汽車是主要的下游需求領域，消費占比約為42%；其次是航空航天，消費比重約為18%；模具和工程機械分別為數控機械第三和第四消費領域，占比分別在15%和10%左右。

未來，隨著智慧手機的逐步普及、更新換代速度的加快，平板電腦、可穿戴設備等消費電子產品、通信等3C產業終端設備的推廣及發展，3C行業將迎來發展的春天，消費電子行業產品並成為行業的新增長點，並有力推動應用於該領域的輕型切削數控工具機的發展。

## 數控工具機產品需求結構矛盾升級，高端產品國產化率低

由於中國大陸高檔數控工具機起步較晚，目前國產產能不能滿足國內需求，國內大多數高檔數控工具機依賴進口。2016年，數控工具機專項支持研發的高檔數控系統已累計銷售1000餘套，國內市場佔有率由專項啟動前的不足1%提高到了5%左右，2017年中國大陸高檔數控工具機的國產化率大約在6%左右，依然較小。但從需求方面看，2013年中國大陸高檔數控工具機的需求占比已經達到了10%左右，2017年大約在15-20%之間，與6%的國產化率相比差距甚大。

當前中國大陸製造業亟需從“製造大國”向“製造強國”轉變。中國大陸數控工具機行業經過幾十年的發展，成為了全球最大的產銷國，技術和產能發展迅速，已經具備回應國家製造業轉型的基礎，未來中國大陸數控工具機需求將由中低檔向高檔轉變，換言之高檔數控工具機將具有較大的進口替代空間。

三大趨勢引領，未來中國大陸數控工具機市場將超5000億元

“十三五”規劃的經濟發展重點在於實現經濟增長方式的轉變，先進製造業是傳統製造業的轉型方向，電子資訊、生物工程、新能源新材料等高新

技術產業的發展將為精密、高效、專用數控工具機開闢了新的需求；從地域發展分析，中國大陸東部產業的升級、東北等老工業基地的振興和中西部的開發加快步伐，為數控工具機產業發展提供國內市場；經濟全球化，國際資本和產業向中國大陸的轉移、國際技術和人才的交流、中國大陸國際貿易的強勁發展等，為中國大陸數控工具機產業的發展提供了外部環境，使數控工具機行業處

於難得的戰略發展期。

未來，中國大陸數控工具機行業將主要呈現以下三大發展趨勢：

首先，國產數控工具機綜合競爭力將大幅提高，從而引起國產數控工具機的市場佔有率將出現根本的變化。

其次，一批跨國工具機集團在中國大陸設立的獨資企業或合資企業，如德國德馬吉、美國哈挺、日本小巨人等，當地語系化生產將形成生產能力。

最後，普及型數控工具機產業化將形成。普及型數控工具機和加工中心數控工具機是各類產品中發展最快、所占比重最大的一類產品，也是製造業應用最廣的一類設備。普及型數控工具機作為中檔型數控工具機，已成為消費的主流，其在數控工具機中所占比例已超過30%，增長速度遠高於其他類型工具機，包括數控工具機的增長速度。■

來源《國際金屬加工商情》



**Mazak**  
Your Partner for Innovation



台灣美捷科股份有限公司

www.mazak.com.tw



# 走出一條特殊的途徑，臺灣工具機在世界工廠裡展露鋒芒

**臺**灣工具機的出口量為世界第四，MIT產品已在過去的半個世紀遍布主要工業國，目前積極進軍新興市場。臺灣製造的工具機對全球金屬製造業貢獻良多，多年來因堅持優異的品質與公平的價格使得臺灣工具機持續的在國際上讓各界刮目相看。臺灣工具機之所以能夠引人注目的主要原因是由於它們具有高度的彈性空間，不但能特製、客製化且還有多功能之優勢，故在國際工具機市場中與其他品牌有極大的區別性。

## 2019，進入挑戰的一年

臺灣機械業產值奮戰多年後，2017年突破新臺幣兆元大關，到達1兆1000億元。目標是2025年達成總產值2兆元願景。但不諱言的是受到中美貿易戰的影響，臺灣及全球工具機產業正遭遇挑戰。中國大陸放緩對臺灣工具機進

口，2018年1至10月臺灣工具機出口中國大陸僅微幅成長5%，對美國出口則大幅成長32.6%，應是美國政府呼籲製造業至美投資，帶動美國對資本財及工具機需求增加的結果。預估今年度整體工具機出口金額將達到36億美元，大約較2017年增長8%至10%。然而因中國大陸市場本體的規模十分巨大，短期間在此流失的成長，並無法完全從他處的成长彌平，因此企業的策略依然需重視原有市場。

臺灣是以出口為導向的國家，過去幾十載，因為與全球工業、科技以及經貿的緊密對接，全球化造就了臺灣優秀的產業實力，臺灣機械產業以獨特技術與知識同樣的成就了各地的工業化。

即使前面佈滿未知的挑戰，臺灣的工具機產業一次次以彈性的生產特色回應市場需求，並找出創新與突围之路，在金屬加工產業群雄併起的戰國時代，開創了一條不以標準化以及單一化

量為主軸的工業模式。這一條特殊的途徑是未來臺灣機械生產著持續堅持的目標，利用TIMTOS兩年一度的盛會，再次一覽臺灣的設備。

## 多功能並實惠的工具機-交通工具與新能源發展的大功臣

臺灣工具機最大的特點是有著善於製造「多功能複合機」的實力。臺灣機械生產者在品質、售價、以及售後服務的講究吸引各國買家不斷的回購，並成為忠實客戶。複合機之所以在當今的工業發展日益被重視的原因是他們能精簡化繁瑣加工工程並縮短不必要的耗時及耗能。例如，車銑複合機結合車、銑、鑽、搪等多種功能，有效的縮短工時、簡化夾治具以縮減轉換製程、避免過多人為誤差。不但節省工廠的機械佔地和人力，更大幅提昇了工具機的效能。

在汽車製造業的模具領域中，大型



的高速五軸加工中心以及多種的數控車床是前衛的汽車製造業愈來愈偏好用到的機種。大型高速五軸加工中心的加工運用領域包涵汽車、火車以及太陽能源。由於五軸工具機的多隻手臂可以無死角的加工工件，並確保整體生產過程順暢，大幅減低人工打磨拋光的時間。臺灣的五軸工具機廠商有完成整車的模



**源利電磁工業股份有限公司**  
Uni Magnetic Industrial Co., Ltd  
www.unimag.com.tw



TNEC Hall 2 R0908



**強力磁鐵過濾機**  
磁力高達5000高斯，過濾精度可達10µ！  
完全無耗材，因此只需一台即可滿足過濾的需求。  
適用弱磁性金屬，油性、水性切削液。  
The magnetic force is up to 5000 gauss, makes the filtration efficiency up to 10µ! No consumption at all. Applicable to weakly ferrous metal, oil-based or water-based coolant.



**移動式廢渣回收機**  
不需接電，不需停機，清潔時間短，體積輕巧的移動式廢渣回收機。  
適用金屬屑、非金屬屑、油性、水性切削液。  
None-demands in extra electricity and machinery stoppage, cleaning time shortened. This light and mobile scrap recycling machine is suitable for scraps of metal, non-metal, and oil / water cutting fluids.

**MAKING EXCEPTIONAL FILTERS FOR EVERY INDUSTRY.**



+886-4-781 0900  
unicoltd@ms26.hinet.net  
彰化縣鹿港鎮彰濱工業區  
工業西六路23號

+86-021-5436 5295  
zhuanghua@unimag.com.tw  
上海市徐匯區宜山路991弄19號102室

**ENERGY SAVING**  
SAVES 15% CUTTING FLUID

**HIGH PRECISION**  
HIGH FILTERING PRECISION

**ULTRA CLEAN**  
95% IMPURIFIED RIDDANCE







SINCE 1977

# UFO

One shank for 400 inserts



**Patent Tool Agent Wanted**

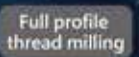

TWTC Hall1, A0424

  
Full profile thread milling

  
Double Corner Radius

  
Concave Radius

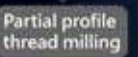
  
Partial profile thread milling

  
T-slot cutter

  
Radius Insert

  
Chamfer Insert

  
Circlip Insert

  
Dovetail Insert

**YIH TROUN ENTERPRISE CO., LTD.**  
www.cut-tools.com.tw

+886-2-8521-3035  
ytservice@cut-tools.com.tw  
No. 1, Lane 403, Hua-Cheng Rd., Hsin-Chuang,  
New Taipei City 24253, Taiwan





型加工能力，是將來發展新材料、新能源交通的重要製造環節。

車體結構加工，諸多臺灣廠商生產針對車體結構製造的車削中心亦在外銷市場中大放異彩。有幾家出色的廠商製造的機型採用先進的平行雙主軸雙刀塔結構與高效率的自動化週邊設備，讓使用者從入料、正面、背面加工、出料、工件檢測的程式可以一氣呵成。此工具機適合各類盤型、短軸型工件之自動化批量生產需求。另外，臺灣的沖床製造大廠生產的設備適合汽車製造領域的厚鋼板成形工作。由於具有高速下降、低速加工特性，所以能大幅降低振動及噪音，提高模具壽命。這類型以高精度方式處理車體結構切削的設備則因為臺灣廠商近年來隨著汽車鈹金的多元化，發展出適合各類車體沖壓成型的沖床。

新一代的航太業對材料、綠能、輕量等訴求十分重視。因應這股趨勢，臺灣工具機業者將他們多年在製造設備累積的專業經驗運用在發展高附加價值、高品質的航太工具機產品，例如，航太設備專用機以及重要的基礎設備。臺灣工具機業者將航太業的智能化、高階化及服務化視為產業革新的下一波目標，也是積極爭取參與未來20年倍增的全球民航需求之重要課題。2015年12月，

臺灣成立了「A-I-M航太工具機產業技術大聯盟」，開啟了航太與工具機產業的深度合作，亦推動臺灣工具機在航太業進一步發展。目前，為航太業提供服務的工具機生產商有永進、友嘉、程泰、麗馳、德大、羅翌等，他們致力為航太業供應鏈增值，推動整個航太製造業的發展。

### 智慧手機與電子設備-共同創造了一個偉大的時代

隨著智慧手機的問世，這十幾年來臺灣的工具機與科技大廠共同生產了改變一個時代的通訊工具。手機模具、零件、電子設備除了使用CNC進行高精度切削之外，也經常使用高精度平面磨床、高精度數控內、外圓磨床、無心磨床等進行加工。未來，隨著科技的進展（例如6G的來臨），科技界勢必會實驗不同材質。等著臺灣工具機的高效、高速並高值的工具機一起開啟另一個智慧時代。

### 精密醫療領域

除了國際市場上能輕易觀察到的汽車加工用的工具機以外，事實上臺灣工具機生產商積極的參與醫療器材的

最新發展。臺灣除了在國內的醫療設備有高度成果，也幫助海外醫療用機打基礎。工具機生產者已發展了適合製造醫療器材的精密工具機。例如，超精密加工線切割機可克服鑽、磨、車、銑、削的加工盲點，無硬度限制的加工。以恆溫系統有效控制加工液與機身溫度，達到醫療類所需之高精密加工的溫控條件。這些技術直接挑戰了日本及瑞士工具機大廠，臺灣醫療類工具機的實力關鍵核心。

### 智慧機械正啟航

臺灣地區工具機產業擁有完整的產業鏈，累積多年的經驗與技術，生產滿足航太、汽車、醫療及3C等產業的精密機械。在全球發展工業4.0的趨勢以及政府結合產、學、研積極推動智慧機械下，工具機廠商結合整機、機器人、物聯網、大資料與AI等技術，開發智慧化機械與產線。2017年，機械產值能突破1兆元大關也歸功於臺灣由內而外，垂直以及水平的跨領域大力推行智慧機械之發展。政府、產業與學界正在打造專屬於臺灣的智慧機械與智慧製造之路，從需求面出發，導入研發單位與學界之技術能量，再運用跨領域之資通訊產業的發展成果，來幫助精密機械產業朝向



智慧機械與智慧製造的方向邁進。臺灣的工具機製造商多不大量產牌，未來，小且精的台灣工具機將帶領業者繼續在市場上露鋒芒。

臺灣高水準的工具機生產商擁有軟硬體兼具的特質，並具有豐富的市場經驗，足以瞭解國際市場所需，提供全方位服務，提高了買主尋找符合生產線工具機的便利性。在這個競爭激烈的大時代裡，臺灣工具機業者能與全球製造者一同掌握工業脈動，為製造業創造不同凡響的工業附加價值。■

來源：榮格工業傳媒

MADE IN TAIWAN

**CHG** 詮豐精密工具股份有限公司  
CHUNG HONG PRECISION TOOL MFG.

▶ **線性傳動的新領域**



[www.chpt.com.tw](http://www.chpt.com.tw)

**PAT.**

**Planetary Screw Assemblies**  
行星式滾柱螺桿

**TIMTOS** 2019.3/4~3/9  
Nangang Hall 2, S0207

Kaohsiung	+886-7-6381281	chggauge@gmail.com
Taichung	+886-4-22421981	chggauge@gmail.com
China	+86-21-59136471	shqfpt@126.com
Thailand	+66-2-7504225	chgthai@gmail.com

**LCH**  
**High Speed Eco Servo Press**

**LCH** **ECO SERVO**

連傑油壓  
3000

**Energy Saving**  
**Noise Reduction**  
**Higher Production Rate**

**LCH-ES**

**eco**

**72<sup>nd</sup> anniversary**  
**Press Expert**

**TIMTOS**  
TWTC Hall1 1F D0501

**LCH** 連傑油壓工業股份有限公司  
**LIEN CHIEH HYDRAULIC INDUSTRIAL CO., LTD.**  
No.97, Baoxin St., Xizhi Dist., New Taipei City 22173, Taiwan  
Tel: +886-2-8648-3000 ext.320 Fax: +886-2-8648-2000  
lienchieh@Lch.com.tw [www.Lch.com.tw](http://www.Lch.com.tw)



## 永進機械：一甲子的卓越技術，引領工具機踏上智慧智造時代



2019年TIMTOS永進機械聚焦「智慧製造」，推出全新的NFX800B-MPS多軸化智慧彈性製造單元，結合智慧自動化、智慧設備、智慧生產管理三大元素，靈活展現「智慧工廠」的實踐概念。NFX800B-MPS主要鎖定航太產業，針對複雜及高精度工件的加工訴求，在機械設計上加入多項專利及巧思，實現一次裝夾即能完成全工序加工，特別適用於多自由曲面產品及有軸向干涉情況之工件。並且透過整合多個工序，能在最小的佔地面積，發揮最大的生產效能，有效降低生產成本及節省加工時間。同時，以獨特的熱對策技術，含括熱抑制、熱移除及熱補償，確

保機台長時間加工精度的穩定性。在智慧應用上，NFX800B-MPS的五軸工作台搭配搬運系統，進行多床台的自動更換，提高機台在自動化模組搭配及應用的多元性。另外，搭配i-Cube內建智慧感測器，自動收集加工數據，進行大數據分析及雲端運算，並透過iPros MX智慧型製造作業系統與先進的硬體協同運作，設備便能具有多種智慧設備功能，可自動優化加工效率及即時監控機器的健康狀況。除此之外，永進機械自研的i-Direct智慧生產管理系統，以物聯網技術連接現場所有設備，使管理者即使在遠端，也能透過電腦或手機，線上查詢即時的生產狀況，監控設備綜合效

率(OEE)，輕鬆辨別生產過程的問題點，以增加管理效能及產品競爭力。

### 整合軟硬體技術 實現智慧工廠

永進機械以NFX800B-MPS多軸化智慧彈性製造單元，將「智慧智造」實踐概念融入尖端的切削技術中，使精度、剛性以及高功率的極致效能集為一體，是提升產品附加價值的最佳利器。

為呼應展會主題「The Sharpest Edge for Industry 工業4.0 智慧製造」，永進機械將展示嶄新的i-Direct智慧生產管理系統。此系統為物聯網IoT解決方案，能連接所有工廠設備，如CNC、非NC、自動化、CMM及刀具量測系統。i-Direct突破時間及地域的界限，使管理者即使在遠端，也能透過電腦或手機，線上查詢即時的生產狀況，監控設備綜合效率(OEE)，輕鬆辨別生產過程的問題點。

### 永續經營，成為最有附加價值之工具機廠

永進機械擁有65年的製造經驗，在強化設備基礎與傳統工藝的堅持下，亦不斷研發創新技術，並利用嶄新的數位科技與工具機結合，創造更多無限可能。

永進機械專注發展在於兩個領域，以協助客戶邁向工業4.0。首先，永進

機械自研i-Direct可提供即時監控及管理工廠的能力。其次，我們持續在機台開發智慧功能，優化機台的性能和提升使用壽命；開發智慧主軸和軸向系統以提高加工效率，同時減少加工振動，展現出最佳表面粗糙度和刀具壽命。除此之外，還能監控設備的健康狀況，預測未來主軸和軸向系統是否會故障，從而提前進行預知保養，以防止設備突然故障而中斷生產。「永續經營，成為最有附加價值之工具機廠」是我們的願景，永進機械採一貫化生產作業模式，從鑄造到機械製造、機台組裝、檢驗、包裝出貨，皆在永進廠內完成，嚴格把關每一道環節的質量。加上，導入「豐田式生產管理系統(Toyota Production System)」，並將此系統命名為YCMPS (Yeong Chin Machinery Production System)。透過獨有的YCMPS生產模式，每位永進人學習「TPS」精神，於既有的生產體系，實施持續改善作業，以提供客戶優質產品、快速服務及準確交期為目標。未來，永進機械將持續開發多軸、高精度機台，整合機器零組件與夾治具、軟體開發，並且導入智慧生產管理，打造更全方位Total Solution服務。

永進機械工業股份有限公司

電話：+886-4-2562-3211

郵箱：sales@YCMCNC.com

網址：www.YCMCNC.com

攤位號碼：J0618

## 昌勇：優質複合數控車床為無人化工廠鋪路

昌勇在2018年度過了40週年，昌勇在TIMTOS 2019將強化複合車床、專用機以及搭配關節式機械手的新型車床。這些設備將在汽、機車零配件、衛浴設備、腳踏車零配件、航太、醫療零配件、農用噴頭、工業用(轉)接頭、手工具配件等加工領域中大展加工優勢。

HCP-42車銑複合式數控車床多種可

搭配之選配附件，例如：滾齒裝置、油壓/伺服刀塔、單軸銑削裝置、Y軸四軸/八軸側銑裝置、三軸鑽孔/攻牙裝置、多角銑裝置等。可做側面/端面銑削、偏心鑽孔，以及外徑雕刻。可根據客戶加工需求來配置機台。

HC-30N專用機的機身為一體成型的鑄造結構，機台重量約達1,700KG，優勢是可以小型車床進行中度、重度切削。此外，X/Z軸的超大行程設計，跨距寬，能夠加強加工的穩定性。在TIMTOS現場，為體現HC-30N因應自動化趨勢的需求，設備將搭配客製化的單件自動送料專用機，在人力短缺的時代，讓客戶能進行無間段自動加工，增加工作時間、提高機器使用率，HC-30N是目前市場上同級機款中CP值最高的機型。

HCP-42數控車床搭配關節式機械手，是為少量多樣生產量身打造的設備，搭配機械手臂，幫助客戶提高生產效率，降低人事成本及降人為操作疏失的損失及浪費，協助客戶產線升級，逐

步實現產業朝向智慧無人化之目標願景。

JYN-42數控車床搭配門型機械手可做單件自動送料，雙軸伺服控制，以高速度、高精度，提高生產效能與質量，24小時生產，不間斷加工，節省人力成本，實現高速化作業。並且根據客戶毛胚之送料需求，可選擇搭配翻轉站、堆疊升降式料盤、平板式料盤或震動筒方式，進行換/補料，機械手採用手持式人機介面，專用掌上型觸控螢幕，介面明確，客戶導向軟體設計，學習容易，使用方便。

另外，JYN-42數控車床更可選配研磨裝置與自動修砂裝置，接續車床上的研磨工程，提高生產率與生產精度。

### 昌勇客製化開發案例，為客戶提高50%的產能

昌勇的國外客戶是汽車的零件供應商，原先有個產品年產量約5百萬個，零件都委外由走心式CNC車床加工，機器單價高，加工速度慢，生產成本就相對提高。

此客戶在昌勇的協助下開發特殊

沖孔裝置，安裝在昌勇HC系列CNC車床。目前此客戶廠內已有15台機台，成本降低了50%，卻達成加倍產出產能，這是改善了原先客戶依賴委外加工的制約，自己掌控全面的產能與成本。

### 改良自動送料，符合自動化趨勢

談及未來趨勢，昌勇表示，將會調整內、外銷的市場比例，增加內銷需求來制衡近期全球經貿穩定的衝擊。此外，昌勇也十分注重勞力短缺的解決方案，並發展自動化。因此致力於改良與模組化自動送料方式，模組化的設計比起以往採用客製化，能更節省成本與加快交期，協助製造業解決長期的缺工問題。昌勇會持續深耕土耳其和俄羅斯市場，並將觸角朝向東南亞與中東前進。

昌勇實業股份有限公司

電話：+886-4-2615-2157

傳真：+886-4-2615-2161

郵箱：greenway@cnc-lathe.com

網址：www.cnc-lathe.com

攤位號碼：南港一館 L0326



# 大前科技：高速五軸加工中心專家



專訪大前科技總經理張恩生

本屆TIMTOS大前科技的主力是推廣第三代（Compact B系列）天車式龍門五軸加工中心，主要特色是強化五軸加工中心的3大關鍵要素：鋼性、精度、以及加功效率。

這些特色主要是經由以下的設計提高Compact B第三代的整體效能。第一、天車式龍門結構將加工軸全部設計於工件上方，工作台維持不動，維持最佳切削響應；第二，透過一體式的底座提高鋼性；第三，以箱中箱對稱的結構將溫度變化所造成的加工影響降低、提高精度。此外，Compact B採用德國線性馬達驅動，以及義大利進口的扭矩電機二軸頭，改善了傳統機械傳動零件造成的齒輪齒條磨損的問題，大幅提高精度與使用壽命。

大前科技在產品的製造與更新上始終堅持他們創立之初所設立的定位：專注高速的五軸機床，並且專注在航太與汽車模具產業。張恩生總經理表示，這10年來，大前在中國大陸快速發展是因為有清楚的定位，沒有替代性因此得以獨領大型快速五軸機床產業。張恩生總經理也分享，大前科技繼2016年出口到北美市場、且2017年出口至歐洲市場，更在2018年達到數個里程碑：去年大前的五軸機床產量突破了70台，且外銷到德國，是令人振奮的進展。“這樣的產能已經可媲美歐洲品牌了，而且過去鮮少亞洲品牌能夠成功的外銷至德國，這是對大前設備科技的正面肯定。”

談及2020的目標，張恩生總經理表示他們將目標設定於年產量100台，若達到此門檻，大前可望成為全球前五大大型五軸機床供應商。技術與科技是擴大產能與營業規模的根基，除此之外，近期大前正積極增加客戶支持的範疇。包含在中國大陸的分公司成立當地的售服團隊、並且強化自製二軸頭的能力。這些計畫是出自於對客戶的承諾，總經理認為站在客戶的角度規劃售後服務是非常重要的，尤其穩定的二軸頭在台灣或中國大陸的五軸機床製造商裡並不常見，但卻是極為關鍵的系統。因此，為了避免客戶因加工突發的狀況進而影響訂單

損失以及商譽，大前的客戶服務的售服團隊有值得信賴的維修能力，可以就近維修，減少了歐洲地區的廠商因距離造成的時間限制。最後一項客戶支持是建立大前的應用團隊。應用團隊能幫助客戶加速整合五軸機的生產以及應用、提供專業諮詢。憑藉著這些技術優勢與對客戶最實際的服務承諾，大前科技以獨家的科技征戰全球市場，今年歡慶成立的十週年慶(2009-

2019)。成立迄今，大前科技已成功行銷全球各地250台機械，持續運轉中。未來大前將帶著這些經驗與突破性科技往五軸機床更高的領域前進。

**大前科技股份有限公司**  
 電話: +886-4-2565-3080  
 傳真: +886-4-2565-3090  
 郵箱: info@kencnc.com  
 網址: www.kencnc.com  
 攤位號碼: I0616

**精密、卓越工具機领航家** 龍門·五面·五軸專業製造

**SDV-HLA系列**  
 CNC高精密龙门加工中心机 with 自动分度万向铣头模组  
 直结式主轴10000rpm, 两段变速行星式齿轮箱, 最大输出扭力可达907/770Nm

特色: 高刚性正交式自动方向铣头  
 BT-50, 3000rpm,  
 C轴自动最小定位分度5°(1°), ±270°  
 A轴自动最小定位分度5°(1°), ±90°  
 重切削移除率最高可达640cm³/min

自动分度万向铣头模组(ASDH-AC1)  
 荣获2017台湾精品殊荣

**S5A-4732HH (TIMTOS展示机)**  
 CNC五轴龙门加工中心机 - 重切削型  
 特适用于钛合金、不锈钢或其他难削材料之多轴同动加工

www.sigmacnc.com.tw

**TIMTOS 2019** Mar 4-9  
 27th Taipei Int'l Machine Tool Show

NANGANG Exhibition Center, Hall 2, 1st Floor  
**Booth No. P0814**

**新穎機械工業股份有限公司**  
 台中市神冈区庄後里大圳路53号  
 Tel: +886-4-25628000 / Fax: +886-4-25621493  
 E-mail: sigma.cnc@msa.hinet.net

參展商採訪

# 普森精密：無線傳電超音波刀把迎接5G世代

普森公司在TIMTOS 2019將會有兩大展出主軸。第一項是「智慧化主軸診斷系統」，並在展覽中以現場連線的方式即時呈現普森客戶在其他展會攤位的主軸運作實況資訊。而第二項主軸則是普森公司最新開發的「無線傳電超音波刀把」。普森公司以自身開發並已立案申請發明專利的傳電架構，並搭載國內法人機構為電動車無線充電所開發的無線傳電技術，建構成了普森公司高傳輸效率的超音波刀把無線傳電模式。相較於以往同業所使用的有線傳電模式，普森的無線傳電模式有更高的加工效率與品質。「無線傳電超音波刀把」也榮獲2019台灣精品獎的肯定，不僅是台灣主軸業界第一項此類型的產品，更是唯一一個獲獎的公司與產品。

無線傳電超音波刀把突破傳統刀把限制：相較於傳統的有線傳電技術，普森公司的無線傳電超音波刀把所應用的無線傳電模式可以有效降低超音波刀把發熱的問題。轉速可從業界傳統的8000RPM提升到24000RPM。而普森公司發明專利的無線傳電架構，也可將超音波傳電效率由23%提升到46%，大幅提高加工的效率與精度。

您認為金屬加工未來的主要趨動力是甚麼？普森是否有相對應的產品線？

彭森榮總經理：普森公司在2018年呈現了穩定的成長。展望2019世界各國都會陸續開通商用5G網路訊號。屆時不只是手機，甚至各式聯網的家電或電子設備都會需要傳遞大量的電磁訊號。而因金屬製機殼的特性會妨礙其訊號的傳遞，所以工業界勢必要尋找其他的材料替代，而目前看來在高階的手機市場將會以藍寶石與陶瓷材料為主流。然而藍寶石與陶瓷材料都屬特別硬脆的難加工材料，在加工時往往容易造成刀具的耗損與斷裂。在這個情形下，使用超音波加工可以將工件的結構震碎，並增加加工效率與精度、延長刀具壽命。故，因應此趨勢，普森公司開發了「無線傳電超音波刀把」。除了硬體設備的超音波刀把、特殊材質刀具、超音波震盪器之外，普森公司並提供客戶多元材料的超音加工參數加以協助顧客建構完整的超音波加工解決方案。

普森在開發智慧主軸上不遺餘力，

今年所展出的會有甚麼樣的創新？普森在甚麼樣的機緣下投入智慧主軸的發展？

彭森榮總經理：以往提到「智慧製造」或是「工業4.0」都會認為是工具機整機大廠的事，而台灣很多所謂「智能化主軸」也只是配合整機廠的需求在主軸內埋入各式感應器來擷取訊號而已。但普森一直不以此為滿足，我們不斷在思考該如何在台灣邁向智慧製造的道路上貢獻一己之力。在不斷的探索與使用者交流後，我們發現了問題的癥結：許多客戶想要投入智慧製造，然而卻因規模或資金限制下，缺乏大廠所擁有的研發能力進而投入開發。例如，規模僅限幾十人的小廠根本不得其門而入，但此型態的中小企業卻是台灣常見的產業型態與特色。找到了此問題後，普森進而思考，若能夠開發一套系統來服務此類型的客戶，便能夠協助台灣的產業升級。因此普森公司決定投入資源開發「智慧型主軸診斷系統」，透過普森的產量優勢，藉由普森每年出產超過2到3萬支主軸上擷取數據，同時配合普森公司跟國立勤益科大團隊合作開發的軟體系統，

以「雲端科技」將資料傳回伺服器進行「大數據分析」。用戶可以在世界各地以普森開發的手機APP來即時監控主軸上的各項數據，甚至提供更進階的損壞預警服務，透過軟硬體的結合來協助客戶打造智能化工廠。

普森在未來的市場策略與營運目標上有何新計畫？

彭森榮總經理：最近雖然中國大陸市場在中美貿易戰的影響之下景氣成長呈現大幅的放緩，但是普森公司近年來積極拓展日本市場，無論是在整組主軸或是零件代工的訂單都有明顯的成長。普森深信價格競爭並非企業長久經營之計，現在在價格上得利者，未來勢必會因為價格而受傷。因此普森公司未來也會持續以開發創新產品與開拓高端市場為目標，證明台灣廠商也能在中、高端市場闖出一片天。

普森精密主軸工業有限公司

電話：+886-4-2213-5988

郵箱：posa.posa@msa.hinet.net

網址：www.posa-spindle.com

攤位號碼：Q0502

## HOSEA HOSEA PRECISION CO.,LTD.

Tel: 04-2531 9551 http://www.hosea-world.com  
Fax: 04-2535 5734 Email: sales@tanshing.net

### CNC ROTARY TABLE

TIMTOS 2019 Mar.4-9  
27th Taipei Int'l Machine Tool Show  
南港展覽館二館4樓 R0818



HOSEA PRECISION CO., LTD. has been exporting 5 Axis rotary tables for over 15 years and we are the leading supplier of this type of export controlled product.

Over 300 5 Axis Rotary Tables Per Year exported from our Taichung manufacturing facility.

We are the **Largest Supplier** of 5 Axis rotary tables in Taiwan.

Hosea becomes first Taiwanese rotary table manufacturer to obtain AS9100D certificate



#### ACR-4040、APC-400

##### Higher Productivity

Through high-speed exchange of the tray to reduce exchange time from 15 sec to 6 sec.

##### More Concise Mechanical Design

Only through the cam mechanism, you can complete tray ascending, descending, and other actions.





Mar.4-9  
TAIPEI NANGANG Exhibition Center, Hall 1  
BOOTH NO.:10408





E-830

## I TECH SAW

### SAW YOUR IDEA



E-530

### A sawing database with 60000 entries

**Decrease defect rate** Increase production speed



P-501LA



www.everising.com  
evrs@everising.com.tw  
+886-4-2359-3178





# 只需1秒加入,與目標潛在買家聯繫

超競爭時代

要使用哪種方式觸及目標買家?

## 內容決定品牌影響力

為什麼選擇故事行銷?

在當今的資訊時代,各類資訊鋪天蓋地。在浩如煙海的資訊中,如何使你想被人看到的資訊不被淹沒?這就需要有好的故事行銷來突顯你的產品了。除了好的內容之外,還需要有良好的平臺和管道來幫助你迅速推廣,獲取有效銷售資源。

**CREATE  
PROMOTE  
ENGAGE  
OPTIMIZE  
STRATEGY  
ANALYZE  
MARKETING**

全媒體行銷整合策略幫助您建立溝通的橋樑、找到中國、東南亞以及全球潛在買家,並提升品牌價值

### 專業編輯團隊

由榮格的專業編輯與攝影團隊為您定制內容(文章X影片)。

### 正確管道

內容發佈於社群媒體、網站、電子快訊與雜誌

### 目標受眾貫穿全產業鏈

在適當的時間,以適當的媒體形式,接觸到正確的人,真正觸達產業鏈中的決策者

通過4大管道,迅速傳遞您的故事內容,有效觸及9大產業的目標買家

覆蓋9種產業  
+  
2大市場

★醫療設備、金屬加工、工業鐳射、感測器、工業機器人、汽車、航空製造設計、智能製造與工業設備產業  
★中國與東南亞市場

4大宣傳管道



平面與電子版

紙感閱讀  
工業雜誌

174,000+  
訂閱戶



分享再分享  
社群媒體

45,000+  
粉絲



主動出擊  
電子快訊

317,000+  
訂閱戶



拉式推廣  
網站

306,000+  
月均獨立訪客



立即聯繫  
獲取專案服務優惠價格  
sydneylai@ringier.com.hk  
886 23297318

通過案例分享讓您更了解



金豐機器工業股份有限公司

產品報導

**NFX800B-MPS多軸化智慧彈性製造單元**

因應工業4.0時代，永進機械推出全新的NFX800B-MPS多軸化智慧彈性製造單元，結合智慧自動化、智慧設備、智慧生產管理三大元素，靈活展現「智慧工廠」的實踐概念。NFX800B-MPS整合多個工序，實現一次裝夾即能完成全工序加工，並具有獨特的熱對策技術，使精度、剛性以及高功率的極致效能集為一體。另外，NFX800B-MPS的五軸工作臺搭配搬運系統，進行多床台的自動更換，提高機台在自動化模組搭配及應用的多元性。另外，搭配i-Cube內建智慧感測器，自動收集加工數據，並透過iPros MX智慧型製造作業系統與先進的硬體協同運作，可達到自動優化加工效率及即時監控機器健康狀況的功能。加上，永進機械自研的i-Direct智慧生產管理系統，連接現場所有設備，使管理者能即時監控設備綜合效率(OEE)，輕鬆辨別生產過程的問題點，以增加管理效能及產品競爭力。



**永進機械工業股份有限公司**  
電話：+886-4-2562-3211  
傳真：+886-4-2562-6479  
郵箱：sales@YCMCNC.com  
網址：www.ycmcnc.com  
攤位號碼：J0618

**智慧製造解決方案**

海德漢將在亞洲最具領導性機械展覽會之一的TIMTOS 2019期間，於南港2館 Q0124展出目前最熱門的話題-海德漢智慧製造的解決方案，邀請您一同來共襄盛舉，實際體驗精良純熟、品質優異的德國頂級工藝。

海德漢將於南港2館展出三大主題，幫助機械製造商實現極致的智慧機台及提供控制器使用者許多增加生產效益的解決方案，包括如下：

**I. 海德漢智慧製造解決方案所提供下列優異的功能，確保彈性生產中高效率的數據管理：**

A. 海德漢工廠管理監控程式State Monitor



B. 遠端桌面管理員 Remote Desktop Manager

C. 第二延伸螢幕

D. 海德漢DNC

**II. 海德漢智慧量測解決方案：**

智慧機台的必要條件就是要在單機上整合加工與量測製程。海德漢將在搭配TNC 640及ETEL TMK高轉數高扭力直驅馬達的銑車複合加工中心機上進行實際使用全數位式通訊的接觸式探針量測功能展示。

**III. 海德漢新世代觸控面板控制器：**

承襲海德漢親近使用者的風格及優異的性能，推出TNC 620 19吋及新的TNC 640 24吋觸控面板控制器，使用者可以以相當直覺的多點式觸控式面板來操作。其具有堅固耐刮、防反光、允許使用手套操作及偵測掌心等特色。

除此之外，海德漢也會展出ETEL超高速高扭力轉定子TMK，其速度比相似尺寸的傳統馬達快8倍，大幅提升工作的效率。

在現場除了展示搭配TMK扭力馬達的銑車複合機外，銑車複合機更整合了海德漢絕對式角度編碼器RCN與ECA系列，其具有絕佳的精度、絕佳防護等級(IP 67)、高相容性、大內徑、易安裝等，使複雜的銑車加工零件的生產更有效率與精準。

海德漢將於展覽期間內，每天將舉辦精采的產品說明會，主題分別為海德漢全閉迴路編碼器工藝，與多功能TNC 640銑車加工。

歡迎各位產業先進加入海德漢官方帳號：@heidenhaintw；設為好友將免費獲得精美禮物一份。再次誠摯地邀請您一同共享本次TIMTOS知識盛宴。

**海德漢股份有限公司**

電話：+886-4-2358-8977  
傳真：+886-4-2358-8978  
郵箱：info@heidenhain.tw  
網址：www.heidenhain.tw  
攤位號碼：Q0124

**10-13軸車洗複合機**

LICO Machinery Co. 位於台中神岡的利高機械(股)公司有36年的經驗於自動車床的設計製造與應用，利高近10年



來主推的10-13軸車洗複合機擷取了傳統自動車床的速度與CNC車床的精度，再更上一層樓的超越多數車床能做到的精度與速度，靠著專業知識與技術，利高的機器一再的證明能在多數的零件加工上能快過瑞士型機床或雙刀塔機器，當然價格也優於歐日的雙刀塔機台，多數的加工車間在選用CNC車床時選用瑞士型的機床當泛用車床，可是仔細研究後發現少於25%的工件才屬於細長型或微小型的走心車床工件(L/D長徑比大於4倍以上)。

利高歡迎有興趣的公司來研討如何利用利高機器提升競爭力。

**利高機械工業股份有限公司**

電話：+886-4-2563-0950

郵箱：sales@licomachinery.com

網址：www.licomachinery.com

攤位號碼：N-0330

**智能化帶鋸機E-830**

合濟智能化帶鋸機E-830，具有切削快速、操作簡易安全、材料損失小、



動力消耗低、省能源、鋸帶壽命長與維護成本低等優點，可廣泛適用於許多不同材料與各種形狀、大小尺寸工件的鋸切加工。此機種優點為鋸切速度快且穩定，可得到高生產效率、高精度、不需毛邊去除製程的工件。近年來在鋸帶依循工業4.0的目標不斷研發，在系統上增加了I TECH SYSTEM，內含了大數據資料庫及機連網的功能，能利用機台內部資料庫將鋸切資料收集後上傳到後台，做機台驅動率及空轉偏移值的計算，讓使用者更能快速的瞭解機台狀況；而目前最新導入QR CODE管理系統，能讓管理者能更精確的掌握機台使用記錄，QR CODE管理操作工及工件資料，實際記錄使用者及工作工件資料，藉以能有效管理進而提升效率。

**合濟工業股份有限公司**

電話：+886-4-2350-5300

傳真：+886-4-2350-5420

郵箱：evrs@everising.com.tw

網址：www.everising.com

攤位號碼：I0408

**MX-800 雙主軸對向雙刀塔車銑複合機**

新一代雙主軸車銑複合機，採用水平床面加上45度立柱，在高剛性結構的基礎上，左右刀塔可自由選配Y軸銑刀功能，最多共有30刀位。並能搭配內藏式機械手或門型機械手，達到一機台即是一條生產線。客戶在最小佔地面積與最具經濟效益，生產是超乎想像的走心式加工效益

**台灣瀧澤科技股份有限公司**

電話：+886-3-4643-166

傳真：+886-3-4643-674

郵箱：richard.su@takisawa.com.tw

網址：www.takisawa.com.tw

攤位號碼：K0108 Hall 1



**HCP-42 車銑複合數控車床**

HCP-42的棒材容納直徑為Ø42mm，標準使用A2-5主軸，可選擇42型筒夾或是6"油壓三爪夾頭配合，採用全滾柱型線性滑軌配置，寬軌設計，剛性結構強，為客戶提供最佳的車削條件。

具有車削與銑削的複合功能，能提供客戶更多元的工作環境，根據加工需求，來配置機台，此機型可搭配多種選購配件，例如：油壓/伺服刀塔、單軸銑削裝置、Y軸四軸側銑裝置、端面三軸動力裝置、多角銑裝置與C軸功能等。如選配C軸功能，更可用於任意角度之主軸定位和輪廓控制，可做側面/端面銑削、偏心鑽孔，以及外徑雕刻。



**昌勇實業股份有限公司**

電話：+886-4-2615-2157

傳真：+886-4-2615-2161

郵箱：greenway@cnc-lathe.com

網址：www.cnc-lathe.com

攤位號碼：L0326

**五軸立式加工中心機UB-660**

1、T字型超高剛性底座，結合移動式立柱式結構，在大與與重型工件有出色的動態性能和高精度加工



2、擺頭式(B軸主軸)搭配水平旋轉工作台(C軸)，工件沒有翻轉效應，可確保加工件的精度與品質

3、大扭力內藏式主軸主軸，轉速12000rpm、扭力88.3Nm、功率37Kw

4、適用長型與複雜工件，以最小的佔地空間俱備最大化的加工效益

5、複合式工作台工，僅需一次裝夾即可快速完成，提升效率並節省加工時間。

6、油溫冷卻系統採用變頻式水冷卻機，提供主軸/擺頭/轉台保持穩定於最佳溫度運轉，展現高效率與高精度加工特色。

7、兼俱高剛性與高精度於一體的5軸立式加工中心機

**友嘉實業股份有限公司**

電話：+886-4-2359-4075

傳真：+886-4-2359-4873

郵箱：sales@feeler.com

網址：www.feeler.com

攤位號碼：J0330

### SHD-40搖擺頭主軸

普森精密主軸產品種類包含車床主軸、加工中心機主軸、磨床主軸以及伸臂式搪銑床主軸。此外，因應全球客戶對於節能、高品質、高效率的需求，而研發之搖擺頭主軸「SHD-40」，一體成形的設計方式使主軸確實達到體積小、低震動、低噪音及維修便利等節能特性。而普森內藏式主軸的「智能化主軸設計概念」，也透過內建各種感應裝置，針對可能影響主軸加工精度的主軸溫升或震動等因素，達到及時的監控並掌握，使主軸的效能及壽命得到了大幅的提升。



普森在此邀請大家於2019年3/4-3/9於TIMTOS展會期間，撥冗蒞臨普森精密主軸工業的展覽攤位(南港二館一樓Q0502)，給予指教及鼓勵。

普森精密主軸工業有限公司  
電話：+886-4-2213-5988  
傳真：+886-4-2213-5996  
郵箱：posa.posa@msa.hinet.net  
網址：www.posa-spindle.com  
攤位號碼：Q0502

### 快速換模系統

富偉快速換模系統適用於沖床、油壓機、射出機、壓鑄機等機台，內容包含夾模器、舉模器、移模臂、操作箱以及動力來源的氣動泵。使用富偉快速換模，可以讓原本繁瑣浪費時間的鎖模過程變得簡單快速，這大大的減少換模過程中所使用的人力、困難度，也大大的增加換模過程的安全性，減少工安意外。

富偉快速換模系統，是使用油壓驅動，比起傳統的螺絲鎖模，更加簡易安全。並且富偉保證，在停電狀況下，也能夠48小時不洩壓，保障人員、機台安全。富偉產品口碑有目共睹，在台灣、中國，皆是第一家專業於快速換模的製造商，並且在這分秒必爭的時代，富偉不只注重品質，也注重服務，相信富偉，富偉一定為您做到。



富偉精機股份有限公司  
電話：+886-4-8345-196  
傳真：+886-4-8345-197  
郵箱：forwell@forwell.com  
網址：www.forwell.com  
攤位號碼：D0530

### 精密螺帽

盈錫在過去29年來專注於「精密螺帽」生產製造與銷售，為了滿足更多的客戶需求，三年前開始投入高階設備並提供「精密零件製造」的服務，除此之外，日前推出的「軸向力感測器」在市場上的反應也非常熱烈，盈錫一路從傳統走向高科技精密產業，秉持品質至上、服務第一的理念，期望成為世界的「零件供應重鎮」。



盈錫精密工業股份有限公司  
電話：+886-4-2244-7899  
傳真：+886-4-2245-2402  
郵箱：service@yinsh.com  
網址：www.yinsh.com  
攤位號碼：R0814

### CNC五軸龍門加工中心機(重切削型)

特適於鈦合金或其他難削材料之多軸同動加工。特色簡介：

- 全機身採高剛性結構體設計，機

械式同動二軸頭，BC軸傳動採蝸桿蝸輪傳動，搭配自製重切削式兩段變速齒輪箱，加工齒輪模數加大(M=3.5)，齒數比1:1.75及1:7及齒輪式傳動主軸設計，最大重切削扭矩可達到1155N·m。

- Z軸主軸頭軌道設計獨家專利-切削加工抑制振動結構設計，大幅降低難削材料加工的振動，提升加工效率、表面精度與刀具壽命(S5A-HH系列專屬)。

- 全封閉式防濺鍍金護罩，摺疊式操作門且具備超大門寬設計，整體外觀更結合時尚美學及安全防護的人因設計。

- 橫樑安全護欄設計，保護維修人員安全，方便機械維修作業。

- 升降式懸臂操作箱，可隨時調整高度，配合操作者所需。

新穎機械工業股份有限公司

電話：+886-4-2562-8000  
傳真：+886-4-2562-1493  
郵箱：sigma.cnc@msa.hinet.net  
網址：www.sigmacnc.com.tw  
攤位號碼：P0814



## Micro Electric Power-off Brakes

極小型斷電煞車器

**HOT NEW ARRIVAL**

Smaller in diameter than 20mm



Spring applied Brake  
微型彈簧式斷電煞車器

Permanent Magnet Brake  
微型永磁式斷電煞車器



CHAIN TAIL CO., LTD.  
仟岱有限公司 since 1984  
www.chaintail.com

**TIMTOS**  
2019.3/4-3/9  
Nangang Hall 2, S1414



No. 305, Lane 460, Sec. 1, Hsianan Rd.,  
Wujih Dist., Taichung City, 41462 Taiwan  
TEL: 886-4-23353024 FAX: 886-4-23354027

## IT'S ATTITUDE.



Right tool for right job.

High speed cutting tools  
Drilling tools & Boring tools  
Turning & Milling Accessories  
Roughing Milling Cutter  
Fine boring system  
Wrench stellar & Wrench Hexagon



**TIMTOS**  
TWTC Hall 1F A0121

WEI GUAN CUTTING TOOLS CO., LTD.  
緯冠刀具有限公司  
No. 463, Tafeng Rd., Tali District, Taichung City, Taiwan

886-4-24929135 info@wei-guan.com.tw  
886-4-24929256 www.wei-guan.com.tw

產品報導

內藏式主軸MVB1318A

健椿提供各式高精度的主軸，買家除了可以由多款產品中找到符合工廠所需外，亦可針對需求為客戶量身訂製。健椿的五個系列CNC加工中心主軸運作十分紮實並且有極低的偏轉公差。其中內藏式主軸採用德國原廠OTT HSK-A63拉桿系統及搭配自行研發之主軸系統，可以完全達到軸心內孔冷卻功能，並有效抑制軸心熱變位的問題，同時軸承採用油氣潤滑，可長時間進行切削加工之工作，主軸馬達功率達25KW，轉速18000RPM，採用二面拘束刀把系統，可通用在立式加工中心機及中小型龍門加工機。健椿的各項高品質產品將生產的出錯率降至最低，有效幫助產線的順暢運行，並且大幅的延長機械設備的壽命。

健椿工業股份有限公司

電話：+886-4-7910-271

傳真：+886-4-7910-272

郵箱：cnc-spindle@kenturn.com.tw

網址：www.kenturn.com.tw

攤位號碼：Q0804



TPRK\_HSIC系列變頻多段離心式泵浦

主要專用於工具機之冷卻液體加壓泵送，適用液體包括水溶液，低黏稠度，無爆炸性輕油，中性之冷卻潤滑液。

-工業循環系統

-清洗系統

-過濾系統

TPRK\_HSIC 為多段浸

入式離心泵，浸水自吸式，馬達與泵軸採用聯軸器接合，主要動作零件採不鏽鋼結構設計，確保無腐蝕操作。一體式軸封設計，方便替換軸封。採用背負式變頻器提高工作壓力，並能依需求達到不同特性控制。

防護等級：IP54

絕緣等級：F級

大井泵浦工業股份有限公司

電話：+886-2-2636-1123~7

傳真：+886-2-2636-3628

郵箱：walrus.indus@msa.hinet.net

網址：www.walruspump.com/zh-tw

攤位號碼：S0916



聖杰刀庫-引領期望、創新無限

本次展會，聖杰展出的是五軸加工中心機專用的鏈式刀夾刀庫。該產品以一體式設計結合鏈條座及刀位座，能夠大幅簡化組裝之精度及效率，履帶式鏈條結構方式具備運行順暢及低間隙之特色，保證產品的長期使用壽命。刀位與刀倉軌道之間以軸承結合，刀鏈運行因軸承滾動接觸，更加順暢降低整體阻抗，與機電驅動完美匹配，大幅節省成本支出。浮動式驅動座機構，能去除鏈條運行時所產生的弦差，確保機構與鏈條維持穩定之結合關係，不須耗費時間調整間隙；刀庫採取模組化設計理念，刀倉皆預留上層可擴充介面，最多可擴充至120刀；同時，伺服系統透過I/O及提供PLC程式設計，可與任意廠牌控制器及系統做搭配。



聖杰創立於2002年，致力成為全產品生產的刀庫廠，秉持傳統機械業最原始之樸實原味為製作高C/P值產品默默堅持；自2016年底，隨著增建廠區及投入制定全新高效率產線之完成，截至2017年第二季，相同人員編制下，產能有效提升5成，更於2019年正式投入自動化生產線，提供高品質、高穩定的產品。

聖杰堅持「自有品牌」策略發展，同時輔以「顧客」為中心之經營模式，透過客製化符合甚至超越顧客期待將是聖杰未來不懈努力之目標。

聖杰國際股份有限公司

電話：+886-4-2565 3819

傳真：+886-4-2565 0219

郵箱：sjatcms@sanjet.com.tw

網址：www.sanjet.com.tw

攤位號碼：TWTC Hall, G0518

強力磁鐵過濾機

磁力高達5000高斯，過濾精度可達10μ！完全無耗材，因此只需一台即可滿足過濾的需求。適用於弱磁性金屬，油性或水性切削液。

源利磁鐵工業股份有限公司

電話：+886-4-7810-900

傳真：+886-4-7810-901

郵箱：matildalin@unimag.com.tw

網址：www.unimag.com.tw

攤位號碼：R0908



GT-ML800五軸銑車複合加工中心機

本機採用高鋼性一體式龍門型架構，搭載銑車合一高速主軸及五軸同動功能，銑切及車銑功能廣泛運用在多面體及複雜外型工件加工。工件一次性裝載，從粗切銑到精修，達最佳生產效能。本機可串連機械手臂及自動進料系統，智能管理提高生產效率。



新虎將機械工業股份有限公司

電話：+886-4-2683-6919

傳真：+886-4-2683-9900

郵箱：GT@gentiger.com.tw

網址：www.gentiger.com.tw

攤位號碼：J0410

2500噸汽車沖壓生產線



配合重型機器人、快速換模系統、送料系統、清洗機，殘料自動輸送收集，左右側雙移動台面，節省換模時間。使用者可以按照特殊的生產需求調整速度以及設定緩衝系統，此產線全年無休，且24小時自動生產，迪斯研發的HD系列的高速科技，解決了深抽成型效率低的既有問題。由蓄壓器控制快速加壓速度達30-150mm/sec，下降速度可達800mm/sec以及上升速度達600mm/sec或更快。此系列的使用者客戶，市佔率在全球已超過10%，為汽車製造產業的世界前三大廠之一。迪斯為客戶提供了客製化的沖壓生產線，並且運用獨家的加工技術創造可靠及堅固的設備，給予客戶可長時間操作的耐用設備。

迪斯創立於1976年，在油壓機械的專業領域裡，以生產高品質之精密油壓工具機的優良廠商著稱，堅持一貫化製造理念，為客戶創造最優質及高附加價值的油壓機，擁有ISO 9001:2015及CE認證，提供安全及易於使用的介面，至今已銷售至世界80個國家

油壓機從10噸到6000噸，生產機台總量累計超過4500台，成功進軍各大汽車廠及配套廠，已上線沖壓生產線上看50條。迪斯的代表客戶群有龐巴迪、波音、本田、豐田、奧迪、大眾、賓士、沃爾沃、博西華集團、伊萊克斯、奇異家電、海爾、富士康等客戶製造汽車、奇異家電、電子、航天相關產品。

迪斯油壓工業股份有限公司

電話：+886-2-2601-8661

傳真：+886-2-2601-8936

郵箱：sales@spc.com.tw

網址：www.deesgroup.com.tw

攤位號碼：世貿一館1F/D0401

SHINZAWA

精度的絕對值 性價比的最佳選擇

Integrity, Service, Quality and Prominence



▲ SV-50S/65S/76S  
立式綜合加工中心機  
Vertical Machining Center



▲ S56-MT  
動柱式立式綜合加工中心機APC  
Traveling Column Vertical Machining Center



▲ SV-50DT/65DT  
鑽銼攻牙中心機  
Drilling Tapping Center



▲ VB-116/127/147/168/208  
立式綜合加工中心機(硬軌)  
Vertical Machining Center (Box way)



▲ SDC-8/10/12  
SDC-16/22/32  
龍門高速加工中心機  
CNC Double Column Machining Center



SV-85S/110S/130S  
SV-865S/1165S/1365S  
立式綜合加工中心機  
Vertical Machining Center

2019 TIMTOS  
Taipei Int'l Machine Tool Show  
Nangang Hall 2 P1002

震澤精密機械股份有限公司  
Shinzawa Precision Machinery Co., Ltd.

42854 台中市大雅區雅潭路三段537-1號  
TEL: +886-4-25690150 FAX: +886-4-25690165  
E-mail: info-cnc@shinzawa.com.tw



www.shinzawa.com.tw





# HYDRAULIC PRESS MAKER

## ODM & OEM In-House Design and Manufacture

SPC DEES Hydraulic, a hydraulic press manufacturer with factories in Taiwan and China since 1976, is focusing on increasing our manufacturing flexibility, constructing global distribution networks, improving quality standards and reducing manufacturing costs for clients. DEES supplies customers such as Boeing, Honda, Toyota, Audi, Volkswagon, Mercedes-Benz, Volvo, Bosch Group home appliances, Electrolux, GE home appliances, Haier, Foxconn, and more. From 10 to 6,000 ton, DEES provides more than 4,500 custom-made hydraulic presses in the world.



**Dees Hydraulic Industrial Co., Ltd.**

TEL: +886-2-2601-8661 FAX: +886-2-2601-8936

E-mail: sales@spc.com.tw

www.deesgroup.com.tw



**TIMTOS** 2019  
Mar.4-9  
27<sup>th</sup> Taipei Int'l Machine Tool Show  
**Booth No. D0401**

# Quick Die Change System

Customized Designs Available 提供客製化設計

## Features

### For Mechanical Press

- Reduced in Die Change Time.
- Reduced Stock Inventory.
- Diverse Products in Small Batches.
- Improved Productivity and Quality.
- Reduced Labor Cost.
- Improved Operation Safety.
- Shortened Delivery Time.
- Better Working Environment.

## 特點

### 沖床專用快速換模系統

- 減少換模時間
- 多種少量的生產
- 減少存貨
- 降低勞力成本
- 增加操作安全
- 達成快速產銷
- 產量與品質改革
- 改善工廠環境



**TX-Type Die Clamp Series**  
TX型系列夾模器



**TY-Type Die Clamp Series**  
TY型系列夾模器



**Power Unit**  
氣動泵組合



**Die Arm Series**  
移模臂

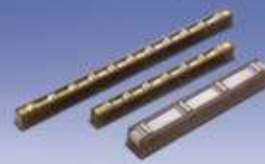

**Die Lifter Series**  
舉模器

**TIMTOS**

**2019**

**Booth No.:**

March 4-9

**D0530**

Taipei World Trade Center Exhibition Hall 1

**AGENT WANTED**

**富偉精機股份有限公司**  
FORWELL PRECISION MACHINERY CO., LTD.

T +886-4-834-5196 F +886-4-834-5197  
E forwell@forwell.com Skype: forwell

**富偉精密機械(寧波)有限公司**  
FORWELL PRECISION MACHINERY (NINGBO) CO., LTD.

T +86-574-8659-9196 F +86-574-8659-9197  
E forwell@forwellnb.com Skype: forwellnb

**富偉機械科技(淮安)有限公司**  
FORWELL MACHINERY TECH (HUAIAN) CO., LTD.

T +86-517-8565-9196 F +86-517-8565-9197  
E forwell@forwellha.com Skype: forwell.ha



Taiwan



Video Online

逛特色商圈

台北的商圈有著令人驚豔的多元風貌，走一趟大稻埕、艋舺、西門町，除了欣賞老建築、感受傳統文化，新世代在此灑下了創意種子、重新詮釋在地文化，讓老街區迸發出迷人的魅力；東區是找尋時髦個性店家的天堂，台北101、信義商圈則展現繁華、時尚的風貌；永康街、中山北路二段的巷弄文化別具特色，不妨在此尋訪風格小店，為旅程增添樂趣。



賞文化藝術

想一睹中華文化數千年前的經典文物，就不能錯過國立故宮博物院的典藏之作，其中以翠玉白菜、肉形石人氣最旺；想親近現代藝術，台北市立美術館、台北當代藝術館、寶藏巖國際藝術村及放映藝術電影的光點台北等，則將藝文融入日常生活。此外，台北街頭也處處充滿藝術氣息，除了隨處可見公共藝術作品，信義商圈、西門町等地常有街頭藝人在此秀才藝，精彩的演出令人讚嘆。

訪文創景點



活化歷史建築讓設計進駐，是臺北文創的精彩之處。前身為酒廠的華山1914文化創意產業園區、原為菸廠的松山文創園區，以及百年市場建築的西門紅樓，還有在大稻埕老屋裡注入文創活水的民藝埕、小藝埕等聚落，或是展現早期眷村風貌的四四南村創意市集，都是能在懷古情調裡遇見臺灣好設計、看好展的尋寶處。

泡溫泉暖湯

在台北最幸福的一件事，就是搭上捷運不用1小時，即可到達煙霧飄渺、綠意圍繞的溫泉鄉——北投。北投的溫泉文化源於日本時代，因此知名景點如溫泉博物館、北投文物館、梅庭均保有濃厚日式風情，而台北市立圖書館北投分館的綠建築及地熱谷白煙裊裊的景觀，也別具特色。在泡湯、賞景之餘不妨順道逛逛北投市場，在巷弄間一探老北投的人文情調。



到廟宇祈福

台北早期的聚落發展，多半依附著廟宇而生，其中有許多超過百年歷史的廟宇，如香火鼎盛的艋舺龍山寺、求姻緣著稱的台北霞海城隍廟、祈求健康的大龍峒保安宮以及大稻埕慈聖宮、關渡宮等，不僅見證了台北城的發展，踏進廟裡更可細細欣賞數百年前精湛的木雕、石刻、剪粘、書畫及栩栩如生的佛像等傳統工藝。



品茗賞美景

位於台北市東南方一隅的貓空，有著城市裡難得一見的茶鄉風情，這裡以種植文山包種茶及鐵觀音聞名，循著蜿蜒的親山步道與茶園走逛，累了不妨在附近的茶館歇歇腿，沏上一壺好茶，享用茶餐，貓空纜車更是當地特色，能以不同視野欣賞翠綠山嵐及茶園美景。此外，同樣可認識茶文化的南港茶葉製造示範場，精選全台道地好茶，提供各式體驗活動，邀請大家來此喝茶聊天。

文字資料提供者：台北市政府觀光傳播局

# 只要一個步驟即可瞭解TIMTOS展覽訊息

今年您除了由榮格工業傳媒承辦的展會快報瞭解TIMTOS展會訊息之外，還可以通過**現場直播**，通過動態影片的即時報導，您可以無時無刻瞭解展會現況。

直播內容包含開幕典禮、採購洽談會、記者會、2019高峰論壇、學生參觀及導覽、工業4.0智慧製造研討會、智慧製造聯網數據增值產業聯盟會員大會、2019年台北國際工具機展歡迎酒會暨工具機研究發展創新產品競賽頒獎典禮、2019台北國際工具機展GLORIA智慧製造創新應用論壇以及展商採訪等等精彩內容。不論您是否在現場，都可以通過直播間，快速瞭解2019年TIMTOS的最新動態。

我們也誠摯邀請您前來榮格攤位獲取其他更多產業訊息，如金屬加工、汽車、醫療、智慧製造等。  
攤位號：南港1館I2138，歡迎前來交流。



掃描QR CODE立即看直播  
▲短影片更適合零碎時間觀看，提升觀看意願

Smart Management

Smart Machines

Smart Automation

與您攜手實踐工業4.0  
Realizing Your Smart Factory Dream



永進機械工業股份有限公司  
YEONG CHIN MACHINERY INDUSTRIES CO., LTD.  
TEL: 886-4-2562-3211 FAX: 886-42562-6479  
www.YCMCNC.com sales@YCMCNC.com



TIMTOS 2019  
27<sup>th</sup> Taipei International Machine Tool Show

Booth No. J0618  
March 4-9, 南港展覽館1館  
Nangang Exhibition Hall 1